



US 20150171148A1

(19) **United States**

(12) **Patent Application Publication**

Song et al.

(10) **Pub. No.: US 2015/0171148 A1**

(43) **Pub. Date: Jun. 18, 2015**

(54) **THIN FILM DEPOSITION APPARATUS,
METHOD OF MANUFACTURING ORGANIC
LIGHT-EMITTING DISPLAY DEVICE BY
USING THE APPARATUS, AND ORGANIC
LIGHT-EMITTING DISPLAY DEVICE
MANUFACTURED BY USING THE METHOD**

Publication Classification

(51) **Int. Cl.**
H01L 27/32 (2006.01)
(52) **U.S. Cl.**
CPC *H01L 27/3218* (2013.01); *H01L 27/3216*
(2013.01)

(71) Applicant: **SAMSUNG DISPLAY CO., LTD.,
YONGIN-CITY (KR)**

(57) **ABSTRACT**

(72) Inventors: **Jung-Bae Song, Yongin-City (KR);
Beohm-Rock Choi, Yongin-City (KR);
Sang-Pil Lee, Yongin-City (KR);
Young-Rok Song, Yongin-City (KR)**

Each of thin film deposition assemblies of a thin film deposition apparatus includes: a deposition source that includes a deposition material; a deposition source nozzle unit arranged at a side of the deposition source and including a plurality of deposition source nozzles arranged in a first direction; a patterning slit sheet arranged opposite to the deposition source nozzle unit and having a plurality of patterning slits arranged in the first direction; and a barrier plate assembly including a plurality of barrier plates arranged in the first direction, the barrier plate assembly being arranged between the deposition source nozzle unit and the patterning slit sheet. The thin film deposition apparatus and the substrate are separated from each other and are movable relative to each other. The deposition material includes a material to produce the thin film of a red (R), green (G) or blue (B) emission layer, or an auxiliary layer.

(21) Appl. No.: **14/542,358**

(22) Filed: **Nov. 14, 2014**

Related U.S. Application Data

(62) Division of application No. 13/093,707, filed on Apr. 25, 2011, now Pat. No. 8,894,458.

Foreign Application Priority Data

Apr. 28, 2010 (KR) 10-2010-0039496
Apr. 5, 2011 (KR) 10-2011-0031288

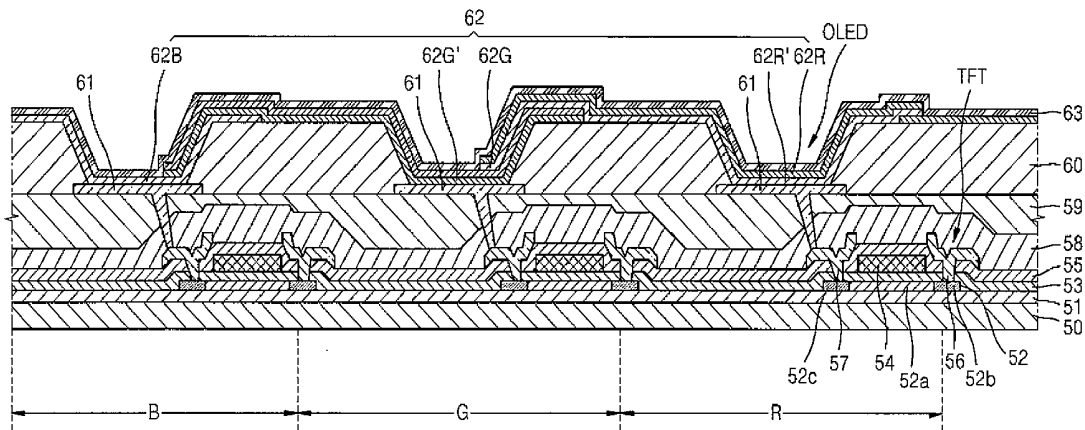

FIG. 1

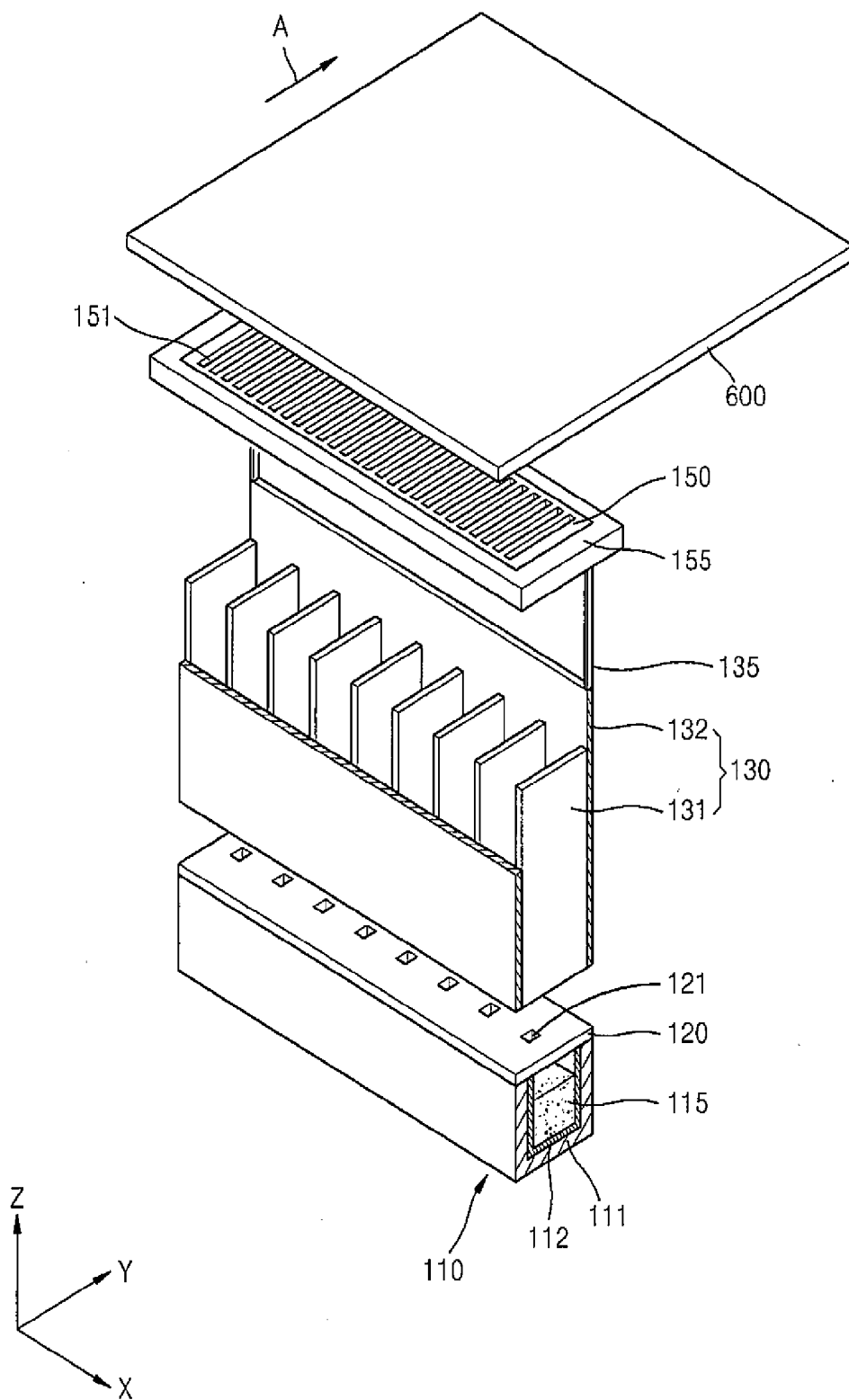

FIG. 2

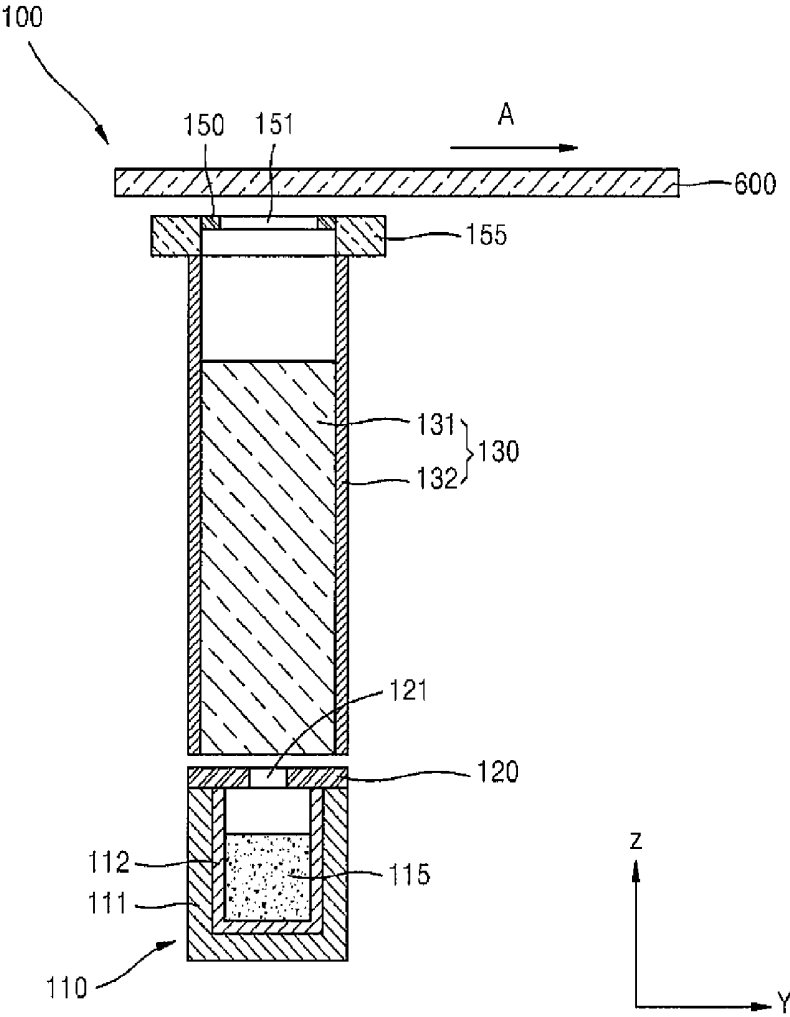

FIG. 3

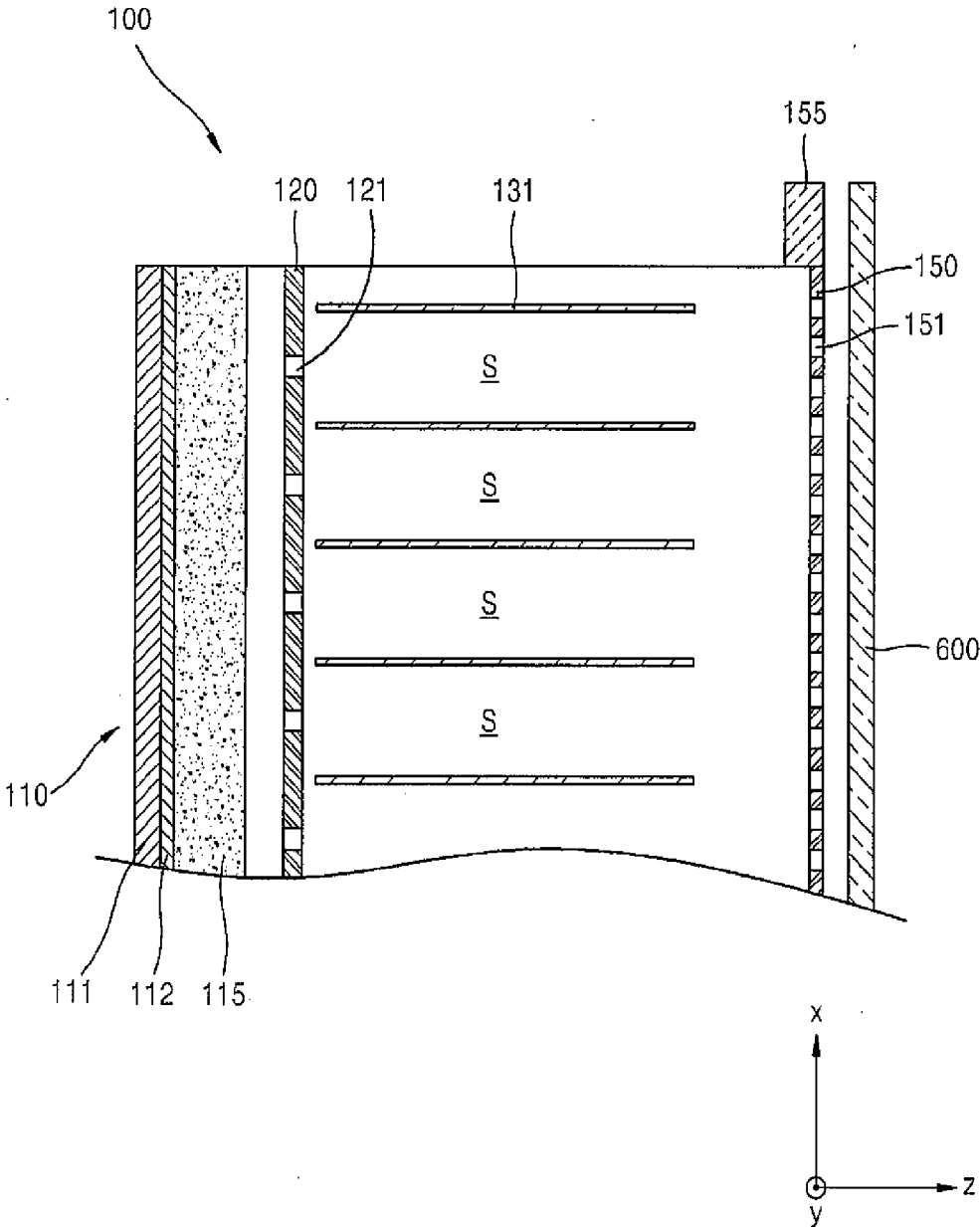

FIG. 4

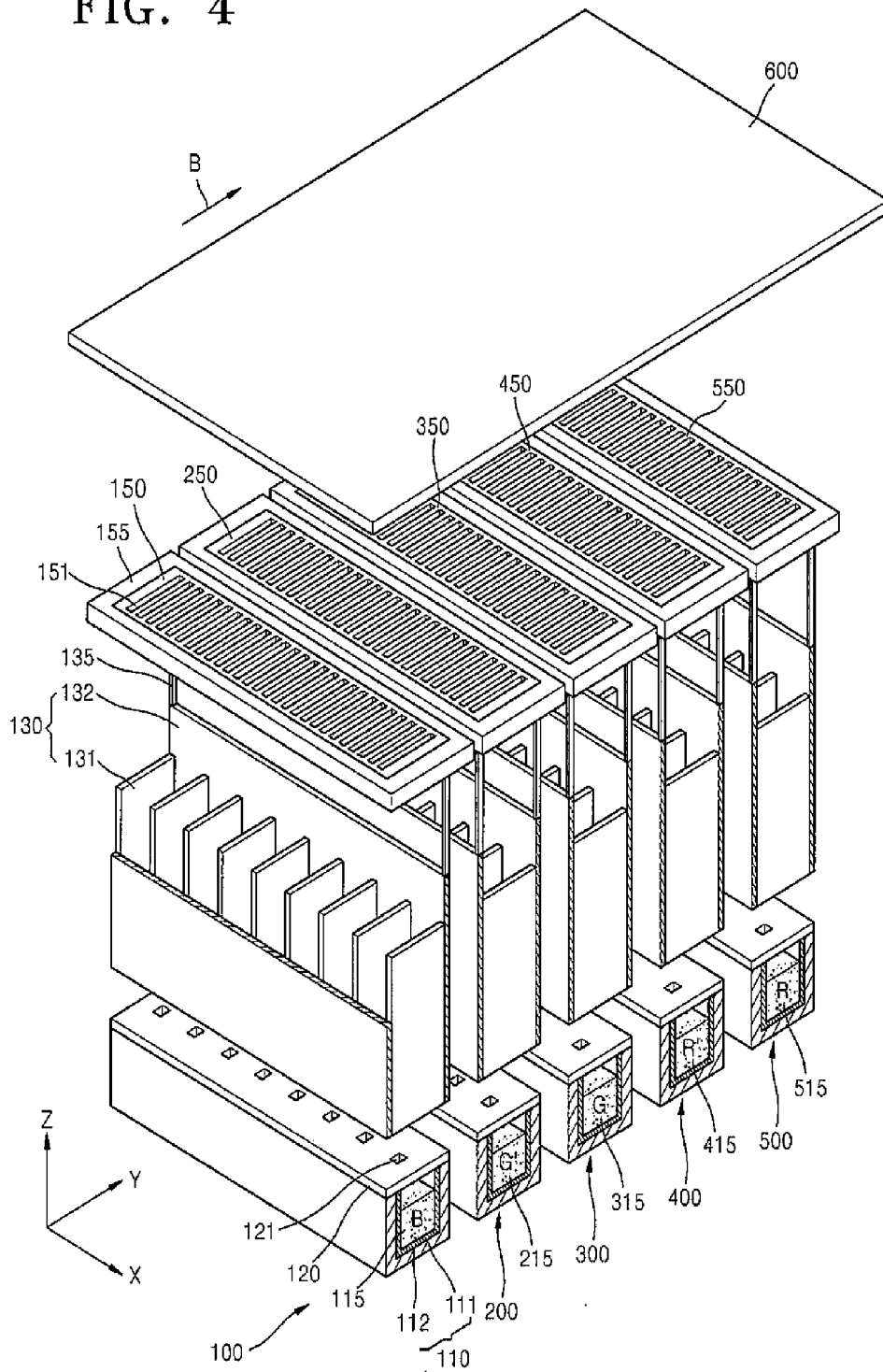

FIG. 5A

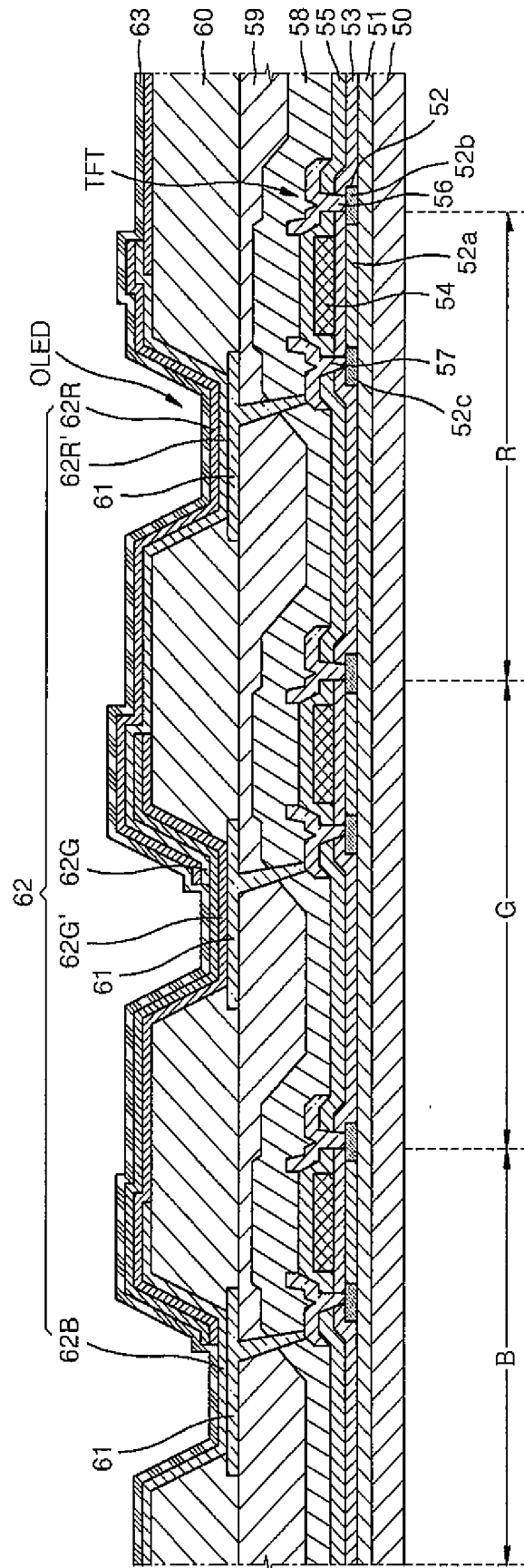

FIG. 5B

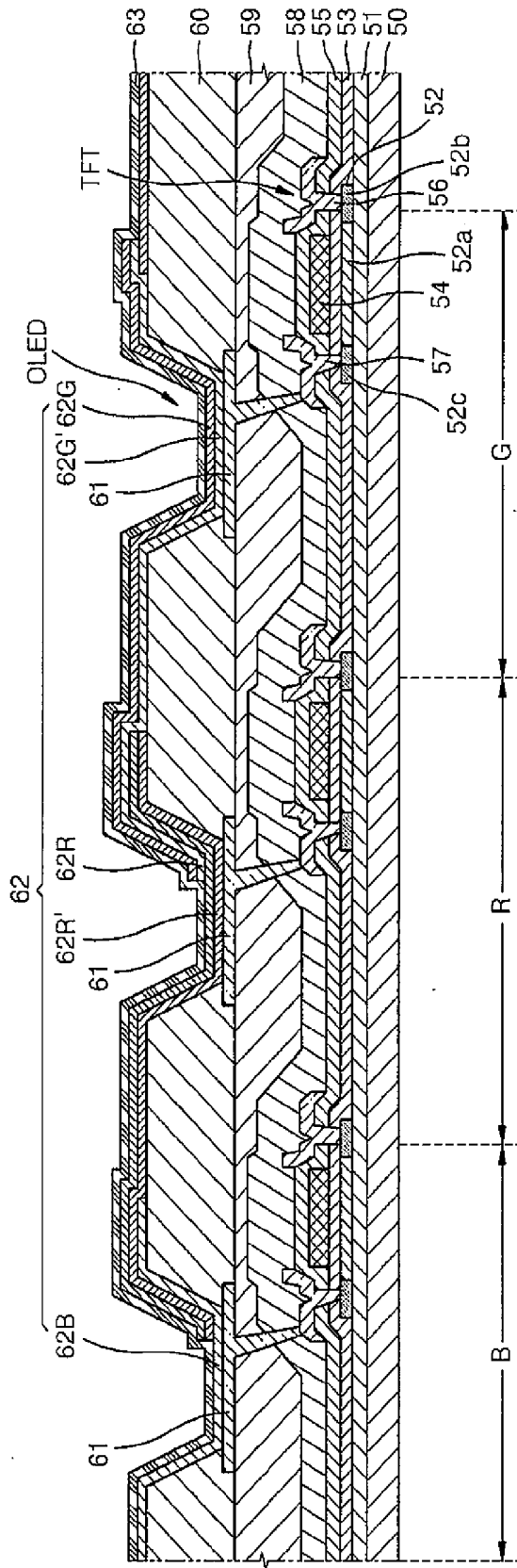

FIG. 6

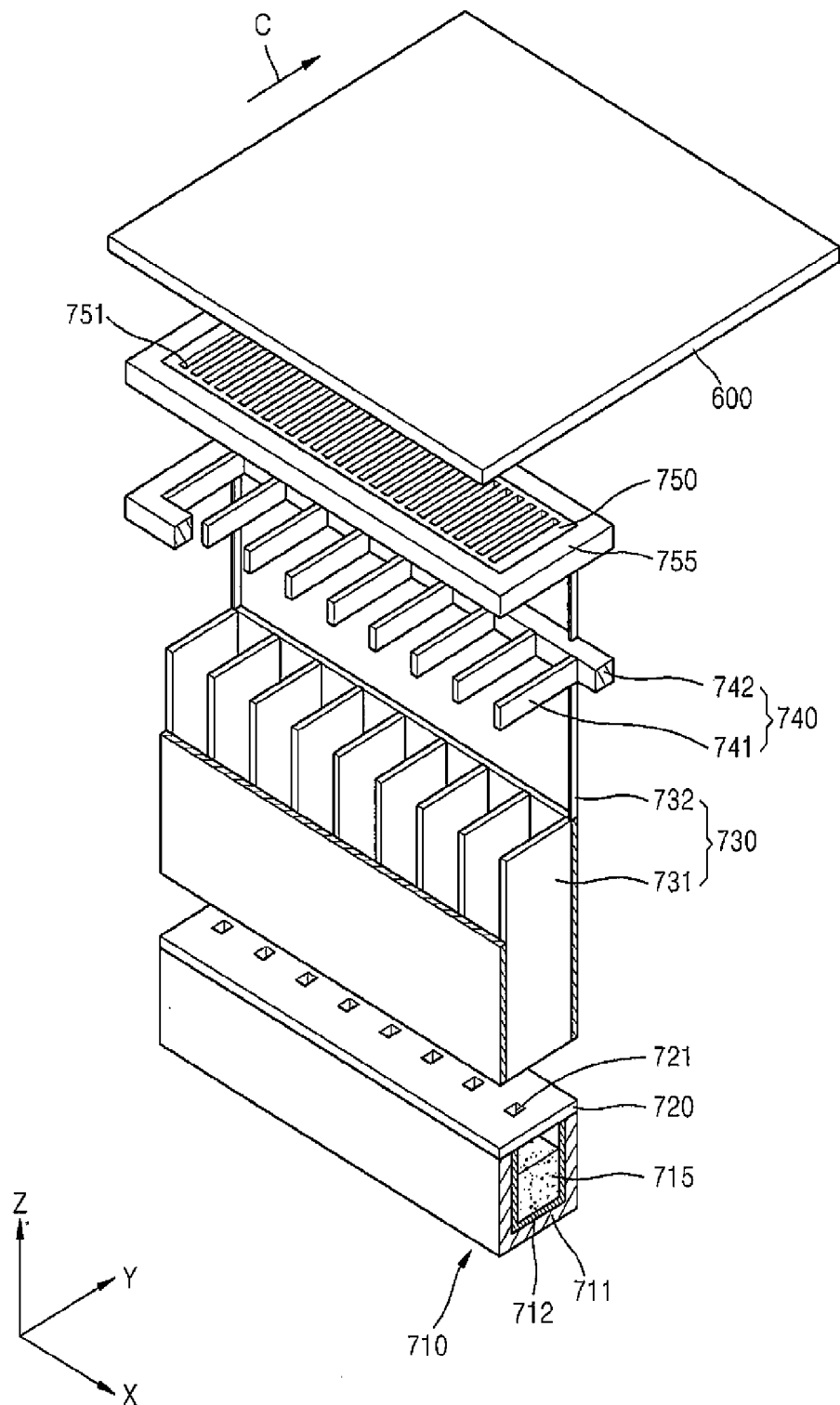

FIG. 7

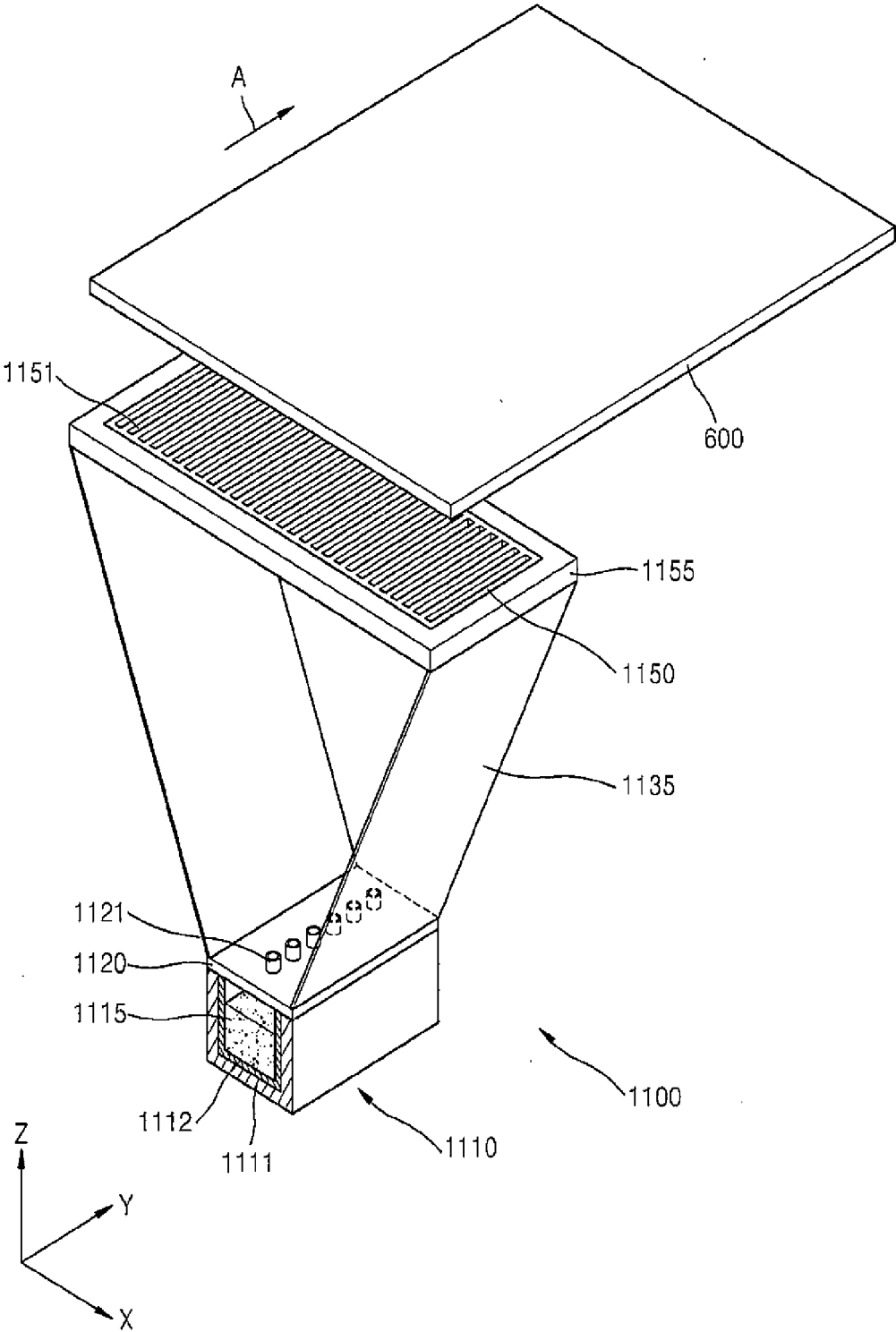

FIG. 8

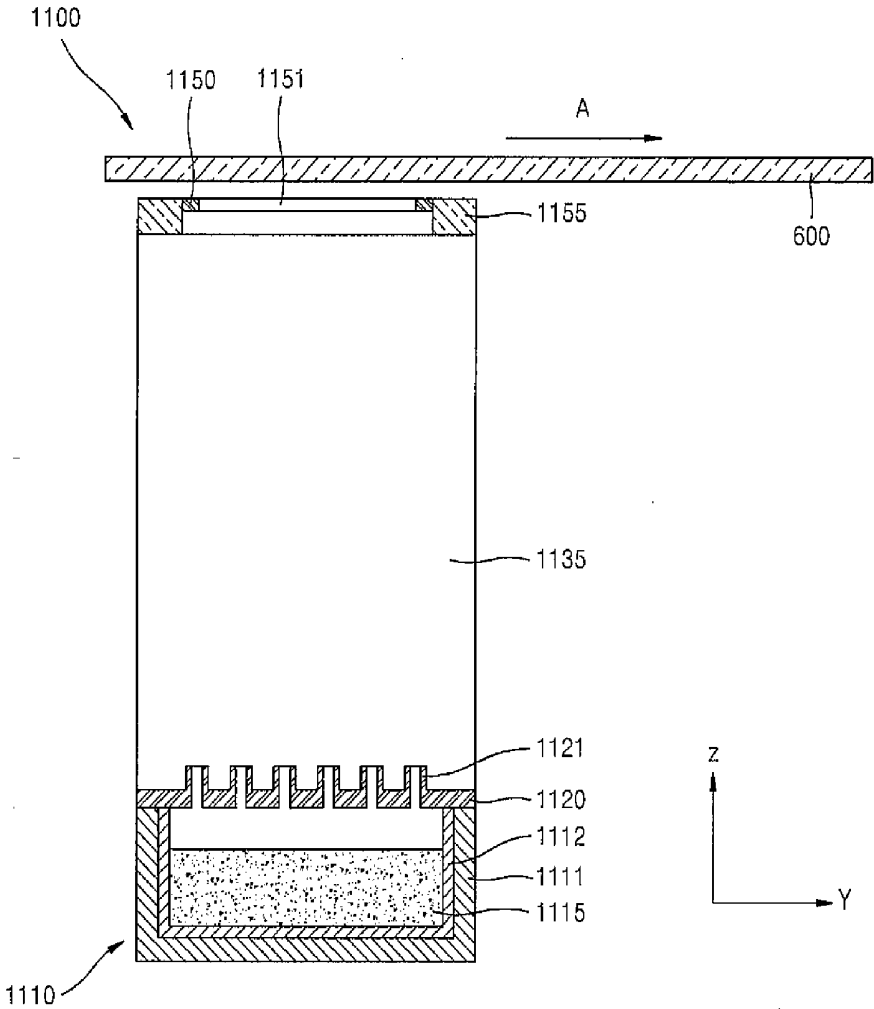

FIG. 9

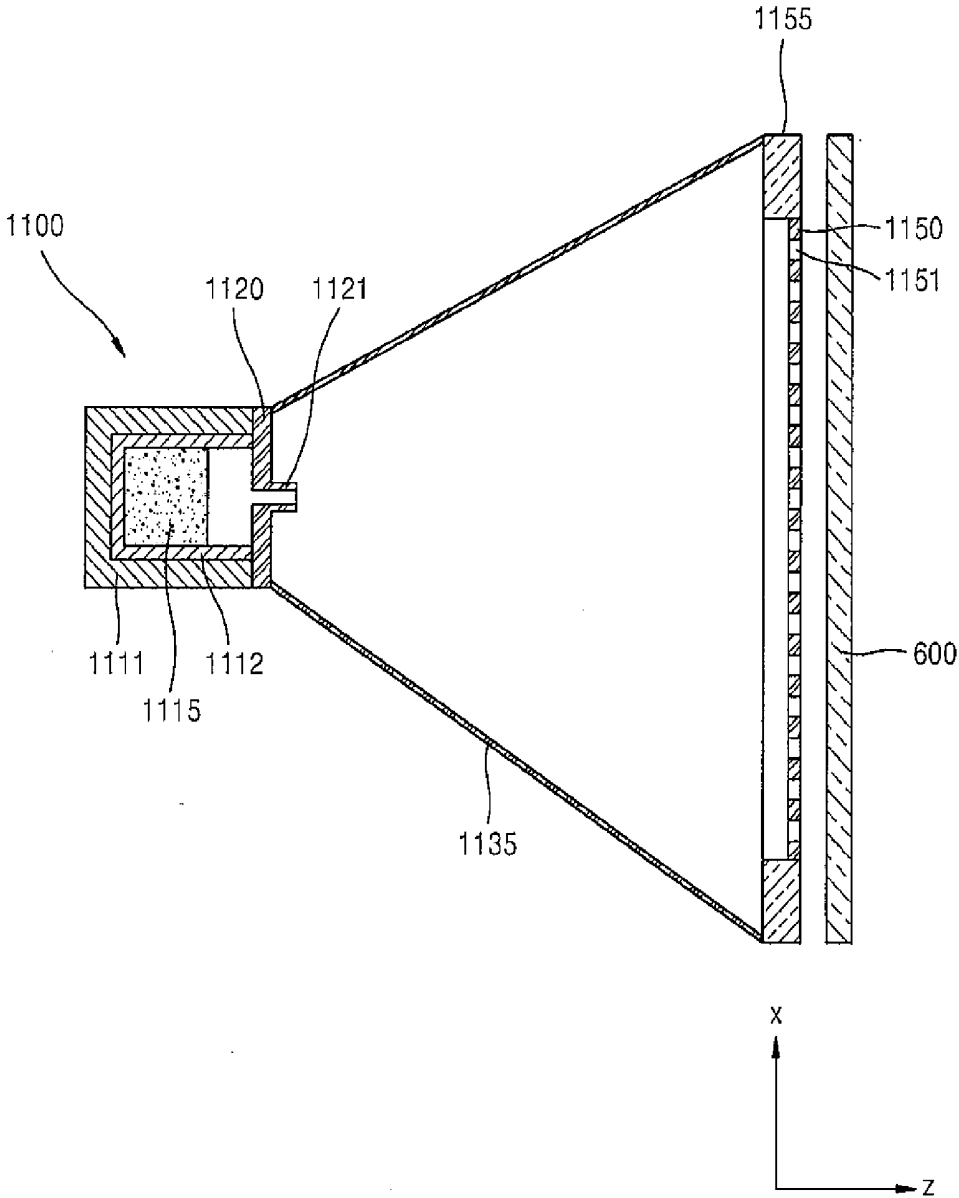

FIG. 10

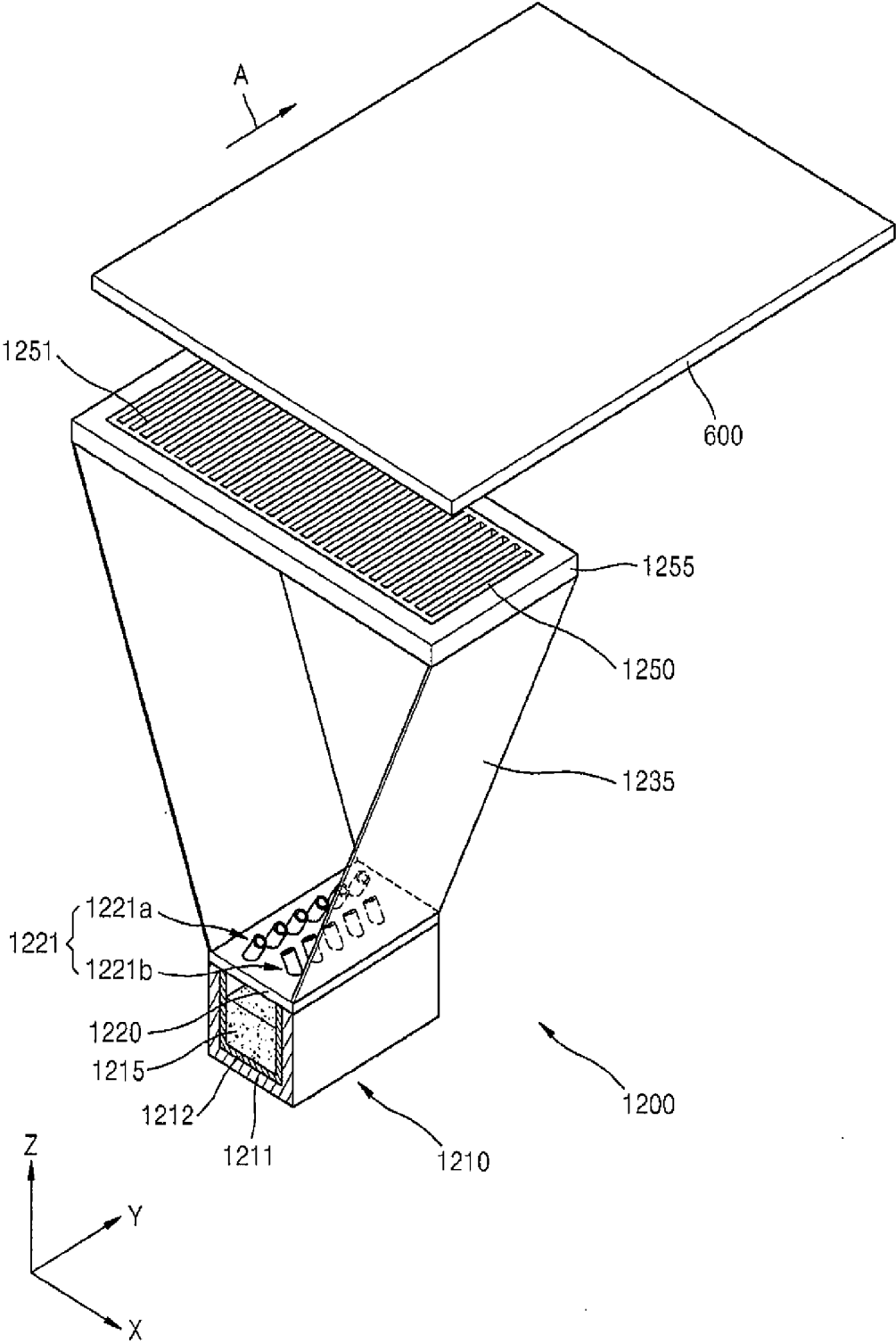

FIG. 11

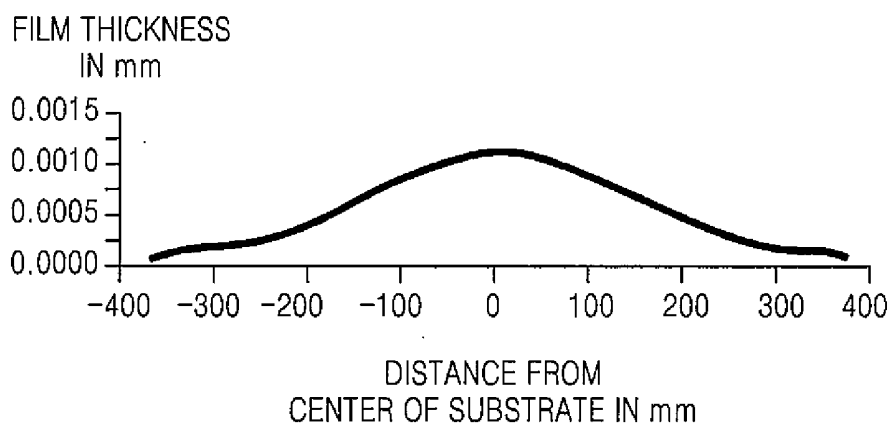

FIG. 12

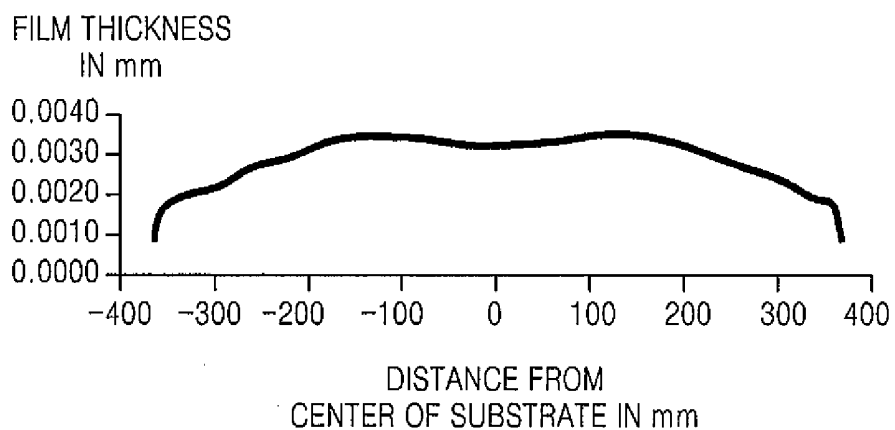

FIG. 13

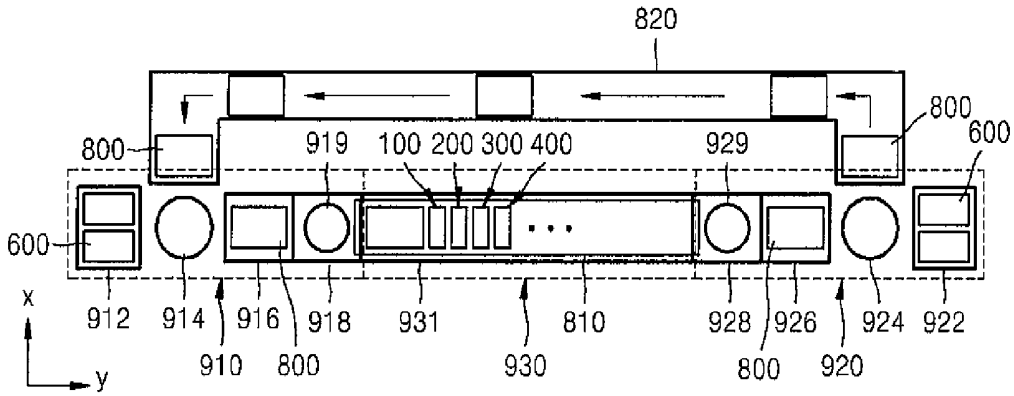

FIG. 14

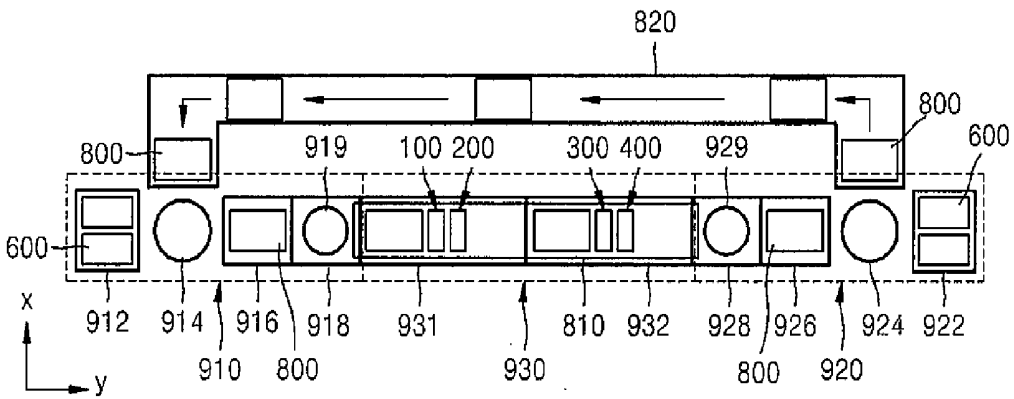
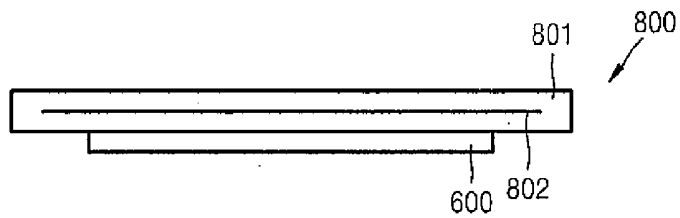

FIG. 15



**THIN FILM DEPOSITION APPARATUS,
METHOD OF MANUFACTURING ORGANIC
LIGHT-EMITTING DISPLAY DEVICE BY
USING THE APPARATUS, AND ORGANIC
LIGHT-EMITTING DISPLAY DEVICE
MANUFACTURED BY USING THE METHOD**

**CROSS-REFERENCE TO RELATED
APPLICATION**

[0001] This application is a divisional of U.S. patent application Ser. No. 13/093,707, filed Apr. 25, 2011, which claims priority to and the benefit of Korean Patent Application No. 10-2010-0039496, filed Apr. 28, 2010 and Korean Patent Application No. 10-2011-0031288, filed on Apr. 5, 2011, in the Korean Intellectual Property Office, the entire contents of all three of which are incorporated herein by reference.

BACKGROUND

[0002] 1. Field

[0003] Embodiments of the present invention relate to a thin film deposition apparatus, a method of manufacturing an organic light-emitting display device by using the thin film deposition apparatus, and an organic light-emitting display device manufactured by using the method.

[0004] 2. Description of the Related Art

[0005] Organic light-emitting display devices have a larger viewing angle, better contrast characteristics, and a faster response rate than other display devices, and thus have drawn attention as a next-generation display device.

[0006] Organic light-emitting display devices generally have a stacked structure including an anode, a cathode, and an emission layer interposed between the anode and the cathode. The devices display images in color when holes and electrons, injected respectively from the anode and the cathode, recombine in the emission layer, and thus light is emitted. However, it is difficult to achieve high light-emission efficiency with such a structure, and thus intermediate layers, including an electron injection layer, an electron transport layer, a hole transport layer, a hole injection layer, or the like, are optionally additionally interposed between the emission layer and each of the electrodes.

[0007] Also, it is practically very difficult to form fine patterns in organic thin films such as the emission layer and the intermediate layers, and red, green, and blue light-emission efficiency varies according to the organic thin films. For these reasons, it is not easy to form an organic thin film pattern on a large substrate, such as a mother glass having a size of 5G or more, by using a conventional thin film deposition apparatus, and thus it is difficult to manufacture large organic light-emitting display devices having satisfactory driving voltage, current density, brightness, color purity, light-emission efficiency, life-span characteristics. Thus, there is a demand for improvement in these regards.

[0008] An organic light-emitting display device includes intermediate layers, including an emission layer disposed between a first electrode and a second electrode that are arranged opposite to each other. The electrodes and the intermediate layers may be formed via various methods, one of which is a deposition method. When an organic light-emitting display device is manufactured by using the deposition method, a fine metal mask (FMM) having the same pattern as a thin film to be formed is disposed to closely contact a

substrate, and a thin film material is deposited over the FMM in order to form the thin film having the desired pattern.

SUMMARY

[0009] Embodiments according to the present invention provide a thin film deposition apparatus that may be easily manufactured, that may be simply applied to the manufacture of large-sized display devices on a mass scale, and that improves manufacturing yield and deposition efficiency, a method of manufacturing an organic light-emitting display device manufactured by using the thin film deposition apparatus, and an organic light-emitting display device manufactured by using the method.

[0010] According to an aspect of the present invention, there is provided a thin film deposition apparatus to produce a thin film on a substrate, the apparatus including a plurality of thin film deposition assemblies, each thin film deposition assembly includes a deposition source that includes a deposition material, the deposition source to discharge the deposition material, a deposition source nozzle unit arranged at a side of the deposition source and including a plurality of deposition source nozzles arranged in a first direction, a patterning slit sheet arranged opposite to the deposition source nozzle unit and having a plurality of patterning slits arranged in the first direction and a barrier plate assembly including a plurality of barrier plates arranged in the first direction, the barrier plate assembly being arranged between the deposition source nozzle unit and the patterning slit sheet, the barrier plate assembly to partition a space between the deposition source nozzle unit and the patterning slit sheet into a plurality of sub-deposition spaces, wherein the thin film deposition apparatus is separated from the substrate by a distance, the thin film deposition apparatus and the substrate are movable relative to each other, deposition material includes a material to produce the thin film selected from the group consisting of a red (R) emission layer, a green (G) emission layer, a blue (B) emission layer and a plurality of auxiliary layers.

[0011] The number of thin film deposition assemblies may be at least five, and deposition materials respectively arranged within the deposition sources of the at least five thin film deposition assemblies may include materials for forming the B emission layer, one of the auxiliary layers, the G emission layer, another of the auxiliary layers, and the R emission layer sequentially. The number of thin film deposition assemblies may be at least five, and deposition materials respectively arranged within the deposition sources of the at least five thin film deposition assemblies may include materials for forming the B emission layer, one of the auxiliary layers, the R emission layer, another of the auxiliary layers, and the G emission layer sequentially. The deposition materials may be respectively arranged within the deposition sources of the plurality of thin film deposition assemblies, and may be sequentially deposited on the substrate. One of the thin film deposition apparatus and the substrate may be movable relative to the other of the thin film deposition apparatus and the substrate along a plane parallel to a surface of the substrate on which the deposition materials are deposited. The patterning slit sheets of the plurality of thin film deposition assemblies may be smaller than the substrate. Deposition temperatures of the deposition sources of the plurality of thin film deposition assemblies may be individually controlled. The barrier plate assembly of each of the thin film deposition assemblies may form a flow path for the deposition materials being discharged from the deposition source. Each of the barrier plates may

extend in a second direction that is substantially perpendicular to the first direction and may partition a space between the deposition source nozzle unit and the patterning slit sheet into the plurality of sub-deposition spaces. Each of the barrier plate assemblies may include a first barrier plate assembly including a plurality of first barrier plates and a second barrier plate assembly including a plurality of second barrier plates. Each of the first barrier plates and each of the second barrier plates may extend in a second direction that is substantially perpendicular to the first direction and partition a space between the deposition source nozzle unit and the patterning slit sheet into a plurality of sub-deposition spaces.

[0012] According to another aspect of the present invention, there is provided a thin film deposition apparatus to produce a thin film on a substrate, the apparatus including a plurality of thin film deposition assemblies, each thin film deposition assembly may include a deposition source that includes a deposition material, the deposition source to discharge the deposition material, a deposition source nozzle unit arranged at a side of the deposition source and including a plurality of deposition source nozzles arranged in a first direction and a patterning slit sheet arranged opposite to the deposition source nozzle unit and having a plurality of patterning slits arranged in a second direction perpendicular to the first direction, wherein deposition is performed while one of the substrate and the thin film deposition apparatus is moved in the first direction relative to another of the substrate and the thin film deposition apparatus, the deposition source, the deposition source nozzle unit, and the patterning slit sheet being integrally arranged as one body, and the deposition material includes a material that produces a thin film selected from the group consisting of a R emission layer, a G emission layer, a B emission layer and a plurality of auxiliary layers.

[0013] The deposition source, the deposition source nozzle unit, and the patterning slit sheet may be integrally connected as one body by a connection member. The connection member may form a flow path for of the deposition material. The connection member may seal a space between the deposition source nozzle unit arranged at the side of the deposition source and the patterning slit sheet. The thin film deposition apparatus may be separated from the substrate by a distance. The deposition material discharged from the thin film deposition apparatus may be continuously deposited on the substrate while one of the substrate and the thin film deposition apparatus is moved in the first direction relative to the other of the substrate and the thin film deposition apparatus. The plurality of deposition source nozzles may be tilted at an angle. The plurality of deposition source nozzles may include deposition source nozzles arranged in two rows extending in the first direction, and the deposition source nozzles in the two rows being tilted to face each other. The plurality of deposition source nozzles include deposition source nozzles arranged in two rows formed in the first direction, the deposition source nozzles of a row located at a first side of the patterning slit sheet are arranged to face a second side of the patterning slit sheet, and the deposition source nozzles of the other row located at the second side of the patterning slit sheet are arranged to face the first side of the patterning slit sheet.

[0014] According to yet another aspect of the present invention, there is provided a method of manufacturing an organic light-emitting display device by using a thin film deposition apparatus to form a thin film on a substrate, the method including arranging the substrate to be separated from the thin film deposition apparatus by a distance, and

depositing a deposition material discharged from the thin film deposition apparatus onto the substrate while one of the thin film deposition apparatus and the substrate is moved relative to the other of the thin film deposition apparatus and the substrate, wherein the thin film deposition apparatus includes a plurality of thin film deposition assemblies, each of said thin film deposition assemblies includes a deposition source that includes a deposition material, the deposition source to discharge the deposition material, a deposition source nozzle unit arranged at a side of the deposition source and including a plurality of deposition source nozzles arranged in a first direction, a patterning slit sheet arranged opposite to the deposition source nozzle unit and having a plurality of patterning slits arranged in the first direction and a barrier plate assembly including a plurality of barrier plates arranged in the first direction, the barrier plate assembly being arranged between the deposition source nozzle unit and the patterning slit sheet, the barrier plate assembly to partition a space between the deposition source nozzle unit and the patterning slit sheet into a plurality of sub-deposition spaces, the deposition material may include a material to produce the thin film selected from the group consisting of a red (R) emission layer, a green (G) emission layer, a blue (B) emission layer and a plurality of auxiliary layers.

[0015] According to yet another aspect of the present invention, there is provide a method of manufacturing an organic light-emitting display device by using a thin film deposition apparatus to form a thin film on a substrate, the method including arranging the substrate to be spaced apart from the thin film deposition apparatus by a distance and depositing a deposition material discharged from the thin film deposition apparatus onto the substrate while one of the thin film deposition apparatus and the substrate is moved relative to the other of the thin film deposition apparatus and the substrate, wherein the thin film deposition apparatus includes a plurality of thin film deposition assemblies, each of said thin film deposition assemblies includes a deposition source that includes a deposition material, the deposition source to discharge the deposition material, a deposition source nozzle unit arranged at a side of the deposition source and including a plurality of deposition source nozzles arranged in a first direction and a patterning slit sheet arranged opposite to the deposition source nozzle unit and having a plurality of patterning slits arranged in a second direction perpendicular to the first direction, wherein the deposition material may include a material that produces a thin film selected from the group consisting of a R emission layer, a G emission layer, a B emission layer and a plurality of auxiliary layers.

[0016] The deposition materials for respectively forming the B emission layer, one of the auxiliary layers, the G emission layer, another of the auxiliary layers, and the R emission layer may be respectively discharged from the plurality of thin film deposition assemblies, and may be sequentially deposited on the substrate. The deposition materials for respectively forming the B emission layer, one of the auxiliary layers, the R emission layer, another of the auxiliary layers, and the G emission layer may be respectively discharged from the plurality of thin film deposition assemblies, and may be sequentially deposited on the substrate. The deposition materials respectively arranged within the deposition sources of the plurality of thin film deposition assemblies may be sequentially deposited on the substrate. The depositing of the deposition material onto the substrate further may

include separately controlling deposition temperatures of the plurality of thin film deposition assemblies.

[0017] According to yet another aspect of the present invention, there is provided an organic light emitting display device manufactured by using a thin film deposition apparatus to form a thin film on a substrate, the method including arranging the substrate to be spaced apart from the thin film deposition apparatus by a distance and depositing a deposition material discharged from the thin film deposition apparatus onto the substrate while one of the thin film deposition apparatus and the substrate is moved relative to the other of the thin film deposition apparatus and the substrate, wherein the thin film deposition apparatus includes a plurality of thin film deposition assemblies, each of said thin film deposition assemblies includes a deposition source that includes a deposition material, the deposition source to discharge the deposition material, a deposition source nozzle unit arranged at a side of the deposition source and including a plurality of deposition source nozzles arranged in a first direction and a patterning slit sheet arranged opposite to the deposition source nozzle unit and having a plurality of patterning slits arranged in a second direction perpendicular to the first direction, wherein the deposition material may include a material that produces a thin film selected from the group consisting of a R emission layer, a G emission layer, a B emission layer and a plurality of auxiliary layers.

[0018] According to yet another aspect of the present invention, there is provided an organic light-emitting display device including a plurality of pixels, wherein each of the pixels includes a G sub-pixel that includes a G emission layer and a G auxiliary layer, a R sub-pixel that includes a R emission layer and a R auxiliary layer and a B sub-pixel that includes a B emission layer, the G auxiliary layer is arranged between the B emission layer and the G emission layer, and the R auxiliary layer is arranged between the G emission layer and the R emission layer. An end portion of the G auxiliary layer may overlap an end portion of the B emission layer, the G emission layer may be arranged on the G auxiliary layer. An end portion of the R auxiliary layer may overlap an end portion of the G emission layer, the R emission layer may be arranged on the R auxiliary layer. The B emission layer and the G emission layer may be separated from each other by a first distance, and the G emission layer and the R emission layer may be separated from each other by a second distance. The display may also include a substrate and a first electrode and a second electrode arranged opposite to each other, wherein the B, G, and R emission layers and the G and R auxiliary layers may be arranged between the first and second electrodes. The G auxiliary layer and the R auxiliary layer may have different thicknesses from each other.

[0019] According to still another aspect of the present invention, there is provide an organic light-emitting display device having a plurality of pixels, each of the pixels may include a G sub-pixel that includes a G emission layer and a G auxiliary layer, a R sub-pixel that includes a R emission layer and a R auxiliary layer and a B sub-pixel that includes a B emission layer, the R auxiliary layer may be arranged between the B emission layer and the R emission layer, and the G auxiliary layer may be arranged between the R emission layer and the G emission layer. An end portion of the R auxiliary layer may overlap an end portion of the B emission layer, the R emission layer may be arranged on the R auxiliary layer. An end portion of the G auxiliary layer may overlap an end portion of the R emission layer, the G emission layer may

be arranged on the G auxiliary layer. The B emission layer and the R emission layer may be spaced apart by a first distance, the R emission layer and the G emission layer may be spaced apart by a second distance. The display may also include a substrate and a first electrode and a second electrode arranged opposite to each other, the B, G, and R emission layers and the G and R auxiliary layers may be arranged between the first and second electrodes. The G auxiliary layer and the R auxiliary layer may have different thicknesses from each other.

BRIEF DESCRIPTION OF THE DRAWINGS

[0020] The above and other features and aspects of the present invention will become more apparent by describing in detail exemplary embodiments thereof with reference to the attached drawings in which:

[0021] FIG. 1 is a schematic perspective view of a thin film deposition assembly according to a first embodiment of the present invention;

[0022] FIG. 2 is a schematic sectional view of the thin film deposition assembly illustrated in FIG. 1 according to the first embodiment of the present invention;

[0023] FIG. 3 is a schematic plan view of the thin film deposition assembly of FIG. 1;

[0024] FIG. 4 is a schematic perspective view of a thin film deposition apparatus according to the first embodiment of the present invention;

[0025] FIGS. 5A and 5B are sectional views of a pixel of an organic light-emitting display device manufactured by using the thin film deposition apparatus of FIG. 4;

[0026] FIG. 6 is a schematic perspective view of a thin film deposition assembly according to a second embodiment of the present invention;

[0027] FIG. 7 is a schematic perspective view of a thin film deposition assembly according to a third embodiment of the present invention;

[0028] FIG. 8 is a schematic side view of the thin film deposition assembly of FIG. 7;

[0029] FIG. 9 is a schematic plan view of the thin film deposition assembly of FIG. 7;

[0030] FIG. 10 is a schematic perspective view of a thin film deposition assembly according to a fourth embodiment of the present invention;

[0031] FIG. 11 is a graph schematically illustrating a distribution pattern of a deposition film formed on a substrate when a deposition source nozzle is not tilted in a thin film deposition assembly, according to the fourth embodiment of the present invention;

[0032] FIG. 12 is a graph schematically illustrating a distribution pattern of a deposition film formed on a substrate when a deposition source nozzle is tilted, in the thin film deposition assembly, according to the fourth embodiment of the present invention;

[0033] FIG. 13 is a schematic plan view of a thin film deposition apparatus according to an embodiment of the present invention;

[0034] FIG. 14 is a schematic plan view of a modified example of the thin film deposition apparatus of FIG. 13; and

[0035] FIG. 15 is a cross-sectional view of an example of an electrostatic chuck of FIG. 13 according to an embodiment of the present invention.

DETAILED DESCRIPTION

[0036] Hereinafter, a thin film deposition apparatus according to an embodiment of the present invention and a method of manufacturing an organic light-emitting display device by using the thin film deposition apparatus will be described in detail.

[0037] Turning now to FIGS. 1 through 3, FIG. 1 is a schematic perspective view of a thin film deposition assembly 100 according to a first embodiment of the present invention, FIG. 2 is a schematic sectional view of the thin film deposition assembly 100 illustrated in FIG. 1, and FIG. 3 is a schematic plan view of the thin film deposition assembly 100 illustrated in FIG. 1.

[0038] Referring to FIGS. 1, 2 and 3, the thin film deposition assembly 100 according to the first embodiment of the present invention includes a deposition source 110, a deposition source nozzle unit 120, a barrier plate assembly 130, and a patterning slit sheet 150.

[0039] Although a chamber is not illustrated in FIGS. 1, 2 and 3 for the convenience of explanation, all the components of the thin film deposition apparatus 100 may be disposed within a chamber that is maintained at an appropriate degree of vacuum. The chamber is maintained at an appropriate vacuum in order to allow a deposition material to move in a substantially straight line through the thin film deposition apparatus 100.

[0040] In particular, in order to deposit a deposition material 115 that is emitted from the deposition source 110 and is discharged through the deposition source nozzle unit 120 and the patterning slit sheet 150 onto a substrate 600 in a desired pattern, it is required to maintain the chamber at a high-vacuum state as in a deposition method using a fine metal mask (FMM). In addition, the temperatures of barrier plates 131 and the patterning slit sheet 150 have to be sufficiently lower than the temperature of the deposition source 110. In this regard, the temperatures of the barrier plates 131 and the patterning slit sheet 150 may be about 100° C. or less. This is because the deposition material 115 that has collided with the barrier plates 131 may not be vaporized again when the temperature of the barrier plates 131 is sufficiently low. In addition, thermal expansion of the patterning slit sheet 150 may be reduced or minimized when the temperature of the patterning slit sheet 150 is sufficiently low. The barrier plate assembly 130 faces the deposition source 110 which is at a high temperature. In addition, the temperature of a portion of the barrier plate assembly 130 close to the deposition source 110 may rise by a maximum of about 167° C., and thus a partial-cooling apparatus may be further included if needed. To this end, the barrier plate assembly 130 may include a cooling member.

[0041] The substrate 600, which constitutes a deposition target on which a deposition material 115 is to be deposited, is disposed in the chamber. The substrate 600 may be a substrate for flat panel displays. A large substrate, such as a mother glass substrate, for manufacturing a plurality of flat panel displays, may be used as the substrate 600. Other substrates may also be employed.

[0042] In the first embodiment of the present invention, deposition may be performed while one of the substrate 600 and the thin film deposition assembly 100 is moved relative to the other of the substrate 600 and the thin film deposition assembly 100.

[0043] In particular, in the conventional FMM deposition method, the size of the FMM has to be equal to the size of a

substrate. Thus, the size of the FMM has to be increased as the substrate becomes larger. However, it is neither straightforward to manufacture a large FMM nor to extend an FMM to be accurately aligned with a pattern.

[0044] In order to overcome this problem, in the thin film deposition assembly 100 according to the first embodiment of the present invention, deposition may be performed while one of the thin film deposition assembly 100 and the substrate 600 is moved relative to the other. In other words, deposition may be continuously performed while the substrate 600, which is disposed such as to face the thin film deposition assembly 100, is moved in a Y-axis direction. In other words, deposition is performed in a scanning manner while the substrate 600 is moved in a direction of arrow A in FIG. 1. Although the substrate 600 is illustrated as being moved in the Y-axis direction in FIG. 3 when deposition is performed, the present invention is not limited thereto. Deposition may instead be performed while the thin film deposition assembly 100 is moved in the Y-axis direction, while the substrate 600 is fixed.

[0045] Thus, in the thin film deposition assembly 100 according to the first embodiment of the present invention, the patterning slit sheet 150 may be significantly smaller than a FMM used in a conventional deposition method. In other words, in the thin film deposition assembly 100 according to the first embodiment of the present invention, deposition is continuously performed, i.e., in a scanning manner while the substrate 600 is moved in the Y-axis direction. Thus, lengths of the patterning slit sheet 150 in the X-axis and Y-axis directions may be significantly less than the lengths of the substrate 600 in the X-axis and Y-axis directions. As described above, since the patterning slit sheet 150 may be formed to be significantly smaller than a FMM used in a conventional deposition method, it is relatively easy to manufacture the patterning slit sheet 150 used in embodiments of the present invention. In other words, using the patterning slit sheet 150, which is smaller than a FMM used in a conventional deposition method, is more convenient in all processes, including etching and other subsequent processes, such as precise extension, welding, moving, and cleaning processes, compared to the conventional deposition method using the larger FMM. This is more suitable or advantageous for a relatively large display device.

[0046] In order to perform deposition while the thin film deposition assembly 100 or the substrate 600 is moved relative to the other as described above, the thin film deposition assembly 100 and the substrate 600 may be separated from each other (e.g., separated by a predetermined distance). This will be described later in detail.

[0047] The deposition source 110 that contains and heats the deposition material 115 is disposed at an opposite side of the chamber from the substrate 600. While the deposition material 115 contained within the deposition source 110 is vaporized, the deposition material 115 is deposited on the substrate 600.

[0048] In particular, the deposition source 110 includes a crucible 111 that is filled with the deposition material 115, and a heater 112 that heats the crucible 111 to vaporize the deposition material 115 arranged within the crucible 111, so as to move the vaporized deposition material 115 to the deposition source nozzle unit 120.

[0049] The deposition source nozzle unit 120 is disposed at a side of the deposition source 110 that faces the substrate 600. The deposition source nozzle unit 120 includes a plurality of deposition source nozzles 121 arranged at equal inter-

vals in the X-axis direction. The deposition material 115 that is vaporized from the deposition source 110 passes through the deposition source nozzle unit 120 towards the substrate 600.

[0050] The barrier plate assembly 130 is disposed at a side of the deposition source nozzle unit 120 closest to substrate 600. The barrier plate assembly 130 includes a plurality of barrier plates 131, and a barrier plate frame 132 that covers sides of the barrier plates 131. The plurality of barrier plates 131 may be arranged parallel to each other at equal intervals in the X-axis direction. In addition, each of the barrier plates 131 may be arranged parallel to a YZ plane in FIG. 3, i.e., perpendicular to the X-axis direction. The plurality of barrier plates 131 arranged as described above partitions the space between the deposition source nozzle unit 120 and the patterning slit sheet 150 into a plurality of sub-deposition spaces S (see FIG. 3). In the thin film deposition assembly 100 according to the first embodiment of the present invention, the deposition space is divided by the barrier plates 131 into the sub-deposition spaces S that respectively correspond to the deposition source nozzles 121 through which the deposition material 115 is discharged.

[0051] The barrier plates 131 may be respectively disposed between adjacent deposition source nozzles 121. In other words, each of the deposition source nozzles 121 may be disposed between two adjacent barrier plates 131. The deposition source nozzles 121 may be respectively located at the midpoint between two adjacent barrier plates 131. As described above, since the barrier plates 131 partition the space between the deposition source nozzle unit 120 and the patterning slit sheet 150 into the plurality of sub-deposition spaces S, the deposition material 115 discharged through each of the deposition source nozzles 121 is not mixed with the deposition material 115 discharged through the other deposition source nozzles 121, and the deposition material 115 passes through the patterning slits 151 so as to be deposited on the substrate 600. In other words, the barrier plates 131 guide the deposition material 115, which is discharged through the deposition source nozzles 121, to move straight in the Z-axis direction and not to flow in the X-axis direction.

[0052] As described above, the deposition material 115 is forced to move straight by installing the barrier plates 131, so that a smaller shadow zone may be formed on the substrate 600 compared to a case where no barrier plates are present. Thus, the thin film deposition assembly 100 and the substrate 400 can be separated from each other (e.g., separated by a predetermined distance). This will be described later in detail.

[0053] The barrier plate frame 132, which forms upper and lower sides of the barrier plates 131, maintains the positions of the barrier plates 131, and guides the deposition material 115 discharged from the deposition source nozzles 121 so that the deposition material 115 does not flow in the Y-axis direction. In other words, the barrier plate frame 132 in the embodiment of FIG. 1 includes two opposing barrier frame plates that are spaced from each other along the Y-axis direction with the barrier plates 131 located therebetween. While the barrier frame plate on the left side in FIG. 1 appears as being less in height than the one on the right side, they may have the same height as illustrated in FIG. 2.

[0054] Although the deposition source nozzle unit 120 and the barrier plate assembly 130 are illustrated as being separated from each other by a predetermined distance, the present invention is not limited thereto. In order to prevent the heat emitted from the deposition source 110 from being con-

ducted to the barrier plate assembly 130, the deposition source nozzle unit 120 and the barrier plate assembly 130 may be separated from each other (e.g., separated by a predetermined distance). Alternatively, if a heat insulator is disposed between the deposition source nozzle unit 120 and the barrier plate assembly 130, the deposition source nozzle unit 120 and the barrier plate assembly 130 may be bound together with the heat insulator therebetween.

[0055] In addition, the barrier plate assembly 130 may be constructed to be detachable from the thin film deposition assembly 100. A conventional FMM deposition technique has low deposition efficiency. Deposition efficiency refers to the ratio of a deposition material deposited on a substrate to the deposition material vaporized from a deposition source. The conventional FMM deposition technique has a deposition efficiency of about 32%. Furthermore, in the conventional FMM deposition technique, about 68% of organic deposition material that is not deposited on the substrate remains adhered to a deposition apparatus, and thus reusing the deposition material is not straightforward.

[0056] In order to overcome these problems, in the thin film deposition assembly 100 according to the first embodiment of the present invention, the deposition space is enclosed by using the barrier plate assembly 130, so that the portion of the deposition material 115 that fails to deposit on substrate 600 is mostly deposited on the barrier plate assembly 130. Thus, since the barrier plate assembly 130 is constructed to be detachable from the thin film deposition assembly 100, when a large amount of the deposition material 115 is attached to the barrier plate assembly 130 after a long deposition process, the barrier plate assembly 130 may be detached from the thin film deposition assembly 100 and then placed in a separate deposition material recycling apparatus in order to recover the deposition material 115. Due to the structure of the thin film deposition assembly 100 according to the first embodiment, a reuse rate of the deposition material 115 is increased, so that the deposition efficiency is improved and waste is reduced, thus reducing manufacturing costs.

[0057] The patterning slit sheet 150 and a frame 155 in which the patterning slit sheet 155 is bound are disposed between the deposition source 110 and the substrate 600. The frame 155 may be formed in a lattice shape, similar to a window frame. The patterning slit sheet 150 is bound inside the frame 155. The patterning slit sheet 150 includes a plurality of patterning slits 151 arranged in the X-axis direction. The deposition material 115 that is vaporized in the deposition source 110, passes through the deposition source nozzle unit 120 and the patterning slit sheet 150 on the way to the substrate 600. The patterning slit sheet 150 may be manufactured by etching, which is the same method as used in a conventional technique of manufacturing an FMM, and in particular, a striped FMM.

[0058] In the thin film deposition assembly 100 according to the first embodiment of the present invention, the total number of patterning slits 151 may be greater than the total number of deposition source nozzles 121. In addition, there may be a greater number of patterning slits 151 than there are deposition source nozzles 121. In other words, at least one deposition source nozzle 121 may be disposed between each two adjacent barrier plates 131. Meanwhile, a plurality of patterning slits 151 (e.g., slits 151a and 151b shown in FIG. 2) may be disposed between each two adjacent barrier plates 131. The space between the deposition source nozzle unit 120 and the patterning slit sheet 150 is partitioned by the barrier

plates **131** into sub-deposition spaces **S** that correspond to the deposition source nozzles **121**, respectively. Thus, the deposition material **115** discharged from each of the deposition source nozzles **121** passes through a plurality of patterning slits **151** disposed in the sub-deposition space **S** corresponding to the deposition source nozzle **121**, and is then deposited on the substrate **600**.

[0059] In addition, the barrier plate assembly **130** and the patterning slit sheet **150** may be formed to be separated from each other (e.g., separated by a predetermined distance). Alternatively, the barrier plate assembly **130** and the patterning slit sheet **150** may be connected by a connection member **135**. The temperature of the barrier plate assembly **130** may increase to 100° C. or higher due to the deposition source **110** whose temperature is high. Thus, in order to prevent the heat of the barrier plate assembly **130** from being conducted to the patterning slit sheet **150**, the barrier plate assembly **130** and the patterning slit sheet **150** are separated from each other (e.g., separated by a predetermined distance).

[0060] As described above, the thin film deposition assembly **100** according to the first embodiment of the present invention performs deposition while being moved relative to the substrate **600**. In order to move the thin film deposition assembly **100** relative to the substrate **600**, the patterning slit sheet **150** is separated from the substrate **600** (e.g., separated by a predetermined distance). In addition, in order to prevent the formation of a relatively large shadow zone on the substrate **600** when the patterning slit sheet **150** and the substrate **600** are separated from each other, the barrier plates **131** are arranged between the deposition source nozzle unit **120** and the patterning slit sheet **150** to force the deposition material **115** to move in a straight direction. Thus, the size of the shadow zone that may be formed on the substrate **600** is sharply reduced.

[0061] In particular, in a conventional deposition technique using a FMM, deposition is performed with the FMM in close contact with a substrate in order to prevent formation of a shadow zone on the substrate. However, when the FMM is used in close contact with the substrate, the contact may cause defects. In addition, in the conventional deposition technique, the size of the mask has to be the same as the size of the substrate since the mask cannot be moved relative to the substrate. Thus, the size of the mask has to be increased as display devices become larger. However, it is not easy to manufacture such a large mask.

[0062] In order to overcome this problem, in the thin film deposition assembly **100** according to the first embodiment of the present invention, the patterning slit sheet **150** is disposed to be separated from the substrate **600** (e.g., separated by a predetermined distance). This may be facilitated by installing the barrier plates **131** to reduce the size of the shadow zone formed on the substrate **600**.

[0063] As described above, according to embodiments of the present invention, a mask is formed to be smaller than a substrate, and deposition is performed while the mask is moved relative to the substrate. Thus, the mask can be easily manufactured. In addition, defects caused due to the contact between a substrate and a FMM, which occur in the conventional deposition technique may be prevented. Furthermore, since it is unnecessary to dispose the FMM in close contact with the substrate during a deposition process, the manufacturing time may be reduced. As described above, the shadow zone formed on the substrate **600** may be reduced by install-

ing the barrier plates **131**. Thus, the patterning slit sheet **150** can be separated from the substrate **600**.

[0064] Turning now to FIG. 4, FIG. 4 is a schematic perspective view of a thin film deposition apparatus according to an embodiment of the present invention. Referring to FIG. 4, the thin film deposition apparatus according to the current embodiment of the present invention includes a plurality of thin film deposition assemblies, each of which has the structure of the thin film deposition assembly **100** illustrated in FIGS. 1 through 3. In other words, the thin film deposition apparatus according to the current embodiment of the present invention may include a multi-deposition source that sequentially discharges deposition materials for forming a blue emission (B) layer, a green auxiliary (G') layer, a green (G) emission layer, a red auxiliary (R') layer, and a red (R) emission layer.

[0065] In particular, the thin film deposition apparatus according to the current embodiment of the present invention includes a first thin film deposition assembly **100**, a second thin film deposition assembly **200**, a third thin film deposition assembly **300**, a fourth thin film deposition assembly **400**, and a fifth thin film deposition assembly **500**. Each of the first thin film deposition assembly **100**, the second thin film deposition assembly **200**, the third thin film deposition assembly **300**, the fourth thin film deposition assembly **400**, and the fifth thin film deposition assembly **500** has the same structure as the thin film deposition assembly described with reference to FIGS. 1 through 3, and thus a detailed description thereof will not be provided here.

[0066] The deposition sources **110** of the first thin film deposition assembly **100**, the second thin film deposition assembly **200**, the third thin film deposition assembly **300**, the fourth thin film deposition assembly **400**, and the fifth thin film deposition assembly **500** may contain different deposition materials, respectively.

[0067] For example, the first thin film deposition assembly **100** may contain a deposition material for forming a B emission layer, the second thin film deposition assembly **200** may contain a deposition material for forming a G' auxiliary layer, the third thin film deposition assembly **300** may contain a deposition material for forming a G emission layer, the fourth thin film deposition assembly **400** may contain a deposition material for forming a R' auxiliary layer, and the fifth thin film deposition assembly **500** may contain a deposition material for forming a R emission layer.

[0068] Alternatively and not shown in FIG. 4, the first thin film deposition assembly **100** may instead contain the deposition material for forming a B emission layer, the second thin film deposition assembly **200** may instead contain the deposition material for forming a R' auxiliary layer, the third thin film deposition assembly **300** may instead contain the deposition material for forming an R emission layer, the fourth thin film deposition assembly **400** may instead contain the deposition material for forming a G' auxiliary layer, and the fifth thin film deposition assembly **500** may instead contain the deposition material for forming a G emission layer.

[0069] According to the above structure, the G' auxiliary layer (refer to **62G'** of FIG. 5A) is disposed between the B emission layer (refer to **62B** of FIG. 5A) and the G emission layer (refer to **62G** of FIG. 5A), and the R' auxiliary layer (refer to **62R'** of FIG. 5A) is disposed between the G emission layer (refer to **62G** of FIG. 5A) and the R emission layer (refer to **62R** of FIG. 5A). Alternatively, the R' auxiliary layer may be disposed between the B emission layer and the R emission

layer, and the G' auxiliary layer may be disposed between the G emission layer and the R emission layer as shown in FIG. 5B. That is, since an intermediate layer is disposed between the two adjacent emission layers, the adjacent emission layers do not contact each other. This will be described later in detail with reference to FIG. 5A.

[0070] Here, the deposition materials for forming the R' and G' auxiliary layer, the deposition material for forming the R emission layer, the deposition material for forming the G emission layer, and the deposition material for forming the B emission layer may vaporize at different temperatures from each other. Thus, the temperatures of the deposition sources 110, 210, 310, 410, and 510 of the respective first, second, third, fourth, and fifth thin film deposition assemblies 100, 200, 300, 400, and 500 may be set to be different.

[0071] Although the thin film deposition apparatus according to the current embodiment of the present invention includes five thin film deposition assemblies, the present invention is not limited thereto. In other words, a thin film deposition apparatus according to another embodiment of the present invention may include a plurality of thin film deposition assemblies, each of which contains a different deposition material.

[0072] As described above, a plurality of thin films may be formed at the same time using a plurality of thin film deposition assemblies, and thus manufacturing yield and deposition efficiency are improved. In addition, the overall manufacturing process is simplified, and the manufacturing costs are reduced.

[0073] Organic layers (refer to the organic layer 62 in FIG. 5A) including the emission layer of an organic light-emitting display device may be formed with a thin film deposition apparatus having the structure described above. A method of manufacturing an organic light-emitting display device according to an embodiment of the present invention may include arranging the substrate 600 to be separated from the thin film deposition apparatus (e.g., separated by a predetermined distance); and depositing a deposition material discharged from the thin film deposition apparatus while moving the thin film deposition apparatus or the substrate 600 relative to the other. This will now be described in detail below.

[0074] Initially, the substrate 600 is arranged to be separated from the thin film deposition apparatus (e.g., separated by a predetermined distance). As described above, the thin film deposition apparatus according to an embodiment of the present invention may include patterning slit sheets 150, 250, 350, 450, and 550, each of which is smaller than the substrate 600, and thus may be relatively easily manufactured. Thus, deposition may be performed while either or both of the thin film deposition apparatus and the substrate 600 are moved relative to the other. In other words, deposition may be continuously performed while the substrate 600, which is arranged opposite to the thin film deposition apparatus, is moved in the Y-axis direction. In other words, deposition is performed in a scanning manner while the substrate 600 is moved in a direction of an arrow B in FIG. 4. In addition, the thin film deposition apparatus and the substrate 600 have to be separated from each other (e.g., separated by a predetermined distance) in order to move the thin film deposition apparatus or the substrate 600 relative to the other. For this reason, the substrate 600 is arranged in a chamber (not shown) and is separated from the thin film deposition apparatus (e.g., separated by a predetermined distance).

[0075] Next, a deposition material discharged from the thin film deposition apparatus is deposited on the substrate 600 while the thin film deposition apparatus or the substrate 600 is moved relative to the other. As described above, the thin film deposition apparatus according to an embodiment of the present invention may include the patterning slit sheets 150, 250, 350, 450, and 550, each of which is smaller than the substrate 600, and thus may be relatively easily manufactured. Thus, deposition is performed while the thin film deposition apparatus or the substrate 600 is moved relative to the other. Although FIGS. 1 and 4 illustrate that the substrate 600 is moved in the Y-axis direction while the thin film deposition apparatus is fixed, the present invention is not limited thereto. For example, the substrate 600 may instead be fixed and the thin film deposition apparatus may be moved relative to the substrate 600.

[0076] The thin film deposition apparatus for performing the method of manufacturing an organic light-emitting display device according to the current embodiment of the present invention may include a multi-deposition source that sequentially discharges deposition materials for forming the B emission layer, the G' auxiliary layer, the G emission layer, the R' auxiliary layer, and the R emission layer. Thus, a plurality of organic layers may be simultaneously formed. That is, the thin film deposition apparatus used to perform the method may include a plurality of thin film deposition assemblies, so that the B emission layer (refer to 62B of FIG. 5A), the G' auxiliary layer (refer to 62G' of FIG. 5A), the G emission layer (refer to 62G of FIG. 5A), the R' auxiliary layer (refer to 62R' of FIG. 5A), and the R emission layer (refer to 62R of FIG. 5A) may be formed at the same time with a single multi-deposition source. Thus, the time taken to manufacture the organic light-emitting display device is sharply reduced, and equipment costs are also markedly reduced since less chambers are needed.

[0077] Organic layers 62 of the organic light emitting display device that will be described later may be manufactured by the thin film deposition apparatus. In addition, the thin film deposition apparatus according to the current embodiment may be used to form organic layers or inorganic layers in an organic thin film transistor, and to form various films by using various materials.

[0078] Hereinafter, an organic light emitting display device manufactured by using the thin film deposition apparatus of FIG. 4 will be described in detail.

[0079] Turning now to FIGS. 5A and 5B, FIGS. 5A and 5B are a cross-sectional views of a pixel of the organic light-emitting display device manufactured by using the thin film deposition apparatus of FIG. 4. The pixel of FIG. 5B is substantially similar to the pixel of FIG. 5A, except that the locations of red and green sub-pixels are interchanged. Therefore, the description is provided below primarily in reference to FIG. 5A. Referring to FIG. 5A, a buffer layer 51 is formed on a substrate 50 made out of glass or plastic. A thin film transistor (TFT) and an organic light emitting diode (OLED) are formed on the buffer layer 51.

[0080] An active layer 52 having a predetermined pattern is formed on the buffer layer 51. A gate insulating layer 53 is formed on the active layer 52, and a gate electrode 54 is formed in a predetermined region of the gate insulating layer 53. The gate electrode 54 is connected to a gate line (not shown) that applies a TFT ON/OFF signal. An interlayer insulating layer 55 is formed on the gate electrode 54. Source/drain electrodes 56 and 57 are formed such as to contact

source/drain regions **52a** and **52c**, respectively, of the active layer **52** through contact holes. A passivation layer **58** made out of SiO_2 , SiN_x , or the like, is formed on the source/drain electrodes **56** and **57**. A planarization layer **59** made out of an organic material, such as acryl, polyimide, benzocyclobutene (BCB), or the like, is formed on the passivation layer **58**. A first electrode **61**, which functions as an anode of the OLED, is formed on the planarization layer **59**, and a pixel defining layer **60** made out of an organic material is formed on the first electrode **61**. An opening is formed in the pixel defining layer **60**, and an organic layer **62** is formed on a surface of the pixel defining layer **60** and on a surface of the first electrode **61** exposed through the opening. The organic layer **62** includes an emission layer. The present invention is not limited to the structure of the organic light-emitting display device described above, and various structures of organic light-emitting display devices may be applied to described embodiments of the present invention.

[0081] The OLED displays predetermined image information by emitting red, green or blue light as current flows. The OLED includes the first electrode **61**, which is connected to the drain electrode **56** of the TFT and to which a positive power voltage is applied, a second electrode **63**, which is formed so as to cover the entire sub-pixel and to which a negative power voltage is applied, and the organic layer **62**, which is disposed between the first electrode **61** and the second electrode **63** to emit light. The first electrode **61** and the second electrode **63** are insulated from each other by the organic layer **62**, and respectively apply voltages of opposite polarities to the organic layer **62** to induce light emission in the organic layer **62**.

[0082] The organic layer **62** may include a low-molecular weight organic layer or a high-molecular weight organic material. When a low-molecular weight organic layer is used, the organic layer **62** may have a single or multi-layer structure including at least one layer selected from the group consisting of a hole injection layer (HIL), a hole transport layer (HTL), an emission layer (EML), an electron transport layer (ETL), and an electron injection layer (EIL). Examples of available organic materials may include copper phthalocyanine (CuPc), N,N'-di(naphthalene-1-yl)-N,N'-diphenyl-benzidine (NPB), tris-8-hydroxyquinoline aluminum (Alq3), and the like. The low-molecular weight organic layer may be formed by vacuum deposition. When including a high-molecular weight organic layer, the organic layer **62** may mostly have a structure including a HTL and an EML. In this case, the HTL may be made out of poly(ethylenedioxythiophene) (PEDOT), and the EML may be made out of polyphenylenevinylenes (PPVs) or polyfluorenes. The HTL and the EML may be formed by screen printing, inkjet printing, or the like. The organic layer **62** is not limited to the organic layers described above, and may be embodied in various other ways and still be within the scope of the present invention.

[0083] The first electrode **61** may function as an anode, and the second electrode **63** may function as a cathode. Alternatively, the first electrode **61** may function as a cathode, and the second electrode **63** may function as an anode.

[0084] The first electrode **61** may be a transparent electrode or a reflective electrode. Such a transparent electrode may be made out of indium tin oxide (ITO), indium zinc oxide (IZO), zinc oxide (ZnO), or indium oxide (In_2O_3). Such a reflective electrode may be formed by forming a reflective layer from silver (Ag), magnesium (Mg), aluminum (Al), platinum (Pt), palladium (Pd), gold (Au), nickel (Ni), neodymium (Nd),

iridium (Ir), chromium (Cr) or a compound thereof and forming a layer of ITO, IZO, ZnO, or In_2O_3 on the reflective layer.

[0085] The second electrode **63** may be formed as a transparent electrode or a reflective electrode. When the second electrode **63** is formed as a transparent electrode, the second electrode **63** functions as a cathode. To this end, such a transparent electrode may be formed by depositing a metal having a low work function, such as lithium (Li), calcium (Ca), lithium fluoride/calcium (LiF/Ca), lithium fluoride/aluminum (LiF/Al), aluminum (Al), silver (Ag), magnesium (Mg), or a compound thereof on a surface of the organic layer **62** and forming an auxiliary electrode layer or a bus electrode line thereon from a transparent electrode forming material such as ITO, IZO, ZnO, In_2O_3 , or the like. When the second electrode **63** is formed as a reflective electrode, the reflective layer may be formed by depositing Li, Ca, LiF/Ca, LiF/Al, Al, Ag, Mg, or a compound thereof on the entire surface of the organic layer **62**.

[0086] In the organic light-emitting display apparatus described above, the organic layer **62** including the emission layer may be formed by using a thin film deposition apparatus **100** (see FIG. 1), which is described above. In more detail, the organic layer **62** may include emission layers **62R**, **62G**, and **62B** and auxiliary layers **62R'** and **62G'**. According to the deposition materials used, the emission layers **62R**, **62G**, and **62B** may emit red (R), green (G) and blue (B) color light, respectively. On the other hand, the auxiliary layers **62R'** and **62G'** are made out of the same material forming the HTL, an intermediate layer including the auxiliary layers **62R'** and **62G'** may be formed to be different in R, G, and B sub-pixels, which respectively emit red, green and blue light. This will now be described in detail below.

[0087] One of the first and second electrodes **61** and **63** is a reflective electrode and the other is a semi-transparent electrode or a transparent electrode. Thus, when the OLED is driven, resonance may occur between the first and second electrodes **61** and **63**. Accordingly, when the organic light emitting display device is driven, the light emitted from the emission layers **62R**, **62G**, and **62B** between the first and second electrodes **61** and **63** is resonated between the first and second electrodes **61** and **63** and emitted out of the organic light emitting display device. Thus, luminance and light emitting efficiency may be improved. In order to form the resonant structure, in the organic light-emitting display device manufactured using the thin film deposition apparatus according to the current embodiment, intermediate layer including the auxiliary layers **62R'** and **62G'** in R, G, and B sub-pixels which respectively emit red, green and blue light, may have different thicknesses. That is, since the auxiliary layers **62R'** and **62G'** in the organic layer **62** that is disposed between the first and second electrodes **61** and **63** have thicknesses that are optimized (or suitable) according to the emitted color of the emission layer, excellent driving voltage, high current density, high emission luminance, high color purity, high emitting efficiency, and superior lifespan characteristics may be obtained.

[0088] In a typical organic light emitting display device, the auxiliary layers **62R'** and **62G'** are generally formed on the first electrode **61**, and then, the R emission layer **62R**, the G emission layer **62G**, and the B emission layer **62B** are sequentially formed on the auxiliary layers. However, when the substrate and the patterning slit sheet are separated from each other like in the thin film deposition apparatus for forming an organic light emitting display device according to the current

embodiment, there is a chance, however slight, that a shadow zone may be generated on the substrate. When the shadow zone is generated and the neighboring emission layers are mixed, the light emitting efficiency is degraded and the driving voltage is increased.

[0089] That is, as shown in following Table 1, an external quantum efficiency (EQE) of the B emission layer 62B in a normal state, that is, when there is no overlapping region, is 6.29%. However, the external quantum efficiency of the B emission layer is sharply reduced to 1.53% or 2.76% when only 1% of the R emission layer 62R or the G emission layer 62G overlaps the B emission layer 62B.

TABLE 1

| | Blue over-lapped with 1% of R | Blue (normal) | Blue over-lapped with 1% of G | Green (normal) | Green over-lapped with 1% of R |
|----------------------|-------------------------------|---------------|-------------------------------|----------------|--------------------------------|
| EQE (%) | 1.53 | 6.29 | 2.76 | 12.29 | |
| Efficiency (cd/A) | 0.9 | 3.7 | 5.3 | 50.5 | 26.4 |
| Cx | 0.159 | 0.144 | 0.170 | 0.223 | 0.233 |
| Cy | 0.068 | 0.057 | 0.222 | 0.711 | |
| Peak Wavelength (nm) | 456 | 456 | 455 | 529 | 529 |

[0090] In order to address the above problem, in the organic light emitting display device according to the current embodiment, sub-pixels in one pixel are arranged in an order of B, G, and R sub-pixels, an end portion of the G' auxiliary layer 62G' and an end portion of the G emission layer 62G overlap an end portion of the B emission layer 62B, and an end portion of the

[0092] In this case, the B emission layer 62B is formed first, and then, the G' auxiliary layer 62G' is formed. Here, a right end of the B emission layer 62B and a left end of the G' auxiliary layer 62G' overlap each other to some degree, and then the left end of the G' auxiliary layer 62G' is deposited on the right end of the B emission layer 62B. Next, the G emission layer 62G is formed on the G' auxiliary layer 62G'. That is, since the G' auxiliary layer 62G' is disposed between the B emission layer 62B and the G emission layer 62G, the adjacent B emission layer 62B and G emission layer 62G do not directly contact each other.

[0093] Next, the R' auxiliary layer 62R' is formed. At this time, the right end of the G emission layer 62G and the left end of the R' auxiliary layer 62R' overlap each other to some degree, and then, the left end of the R' auxiliary layer 62R' is deposited on the right end of the G emission layer 62G. After that, the R emission layer 62R is formed on the R' auxiliary layer 62R'. That is, since the R' auxiliary layer 62R' is disposed between the G emission layer 62G and the R emission layer 62R that are adjacent to each other do not directly contact each other.

[0094] As shown in Table 2, an external quantum efficiency of the B emission layer 62B in a normal state, that is, when there is no overlapping region, is 6.29%. In addition, an external quantum efficiency when the R' auxiliary layer and the R emission layer 62R overlap each other by about 1% is 5.78% and an external quantum efficiency when the G' auxiliary layer and the G emission layer 62G overlap each other by about 1% is 5.42%. That is, when compared with Table 1 in which the intermediate auxiliary layers are not disposed between the adjacent emission layers, the light emitting efficiency of the light emission layer is greatly improved, the color mixture does not occur, and the reproduction of color coordinates is improved.

TABLE 2

| | Blue (overlapping R 1% and R' 1%) | Blue (normal) | Blue (overlapping G 1% and G' 1%) | Green (overlapping B 1%) | Green (normal) | Green (overlapping R 1%, R' 1%) | Red (overlapping G 1%) | Red (normal) | Red (overlapping B 1%) |
|----------------------|-----------------------------------|---------------|-----------------------------------|--------------------------|----------------|---------------------------------|------------------------|--------------|------------------------|
| EQE (%) | 5.78 | 6.29 | 5.42 | 11.83 | 12.29 | 10.29 | 26.34 | 27.86 | 28.19 |
| Efficiency (cd/A) | 3.5 | 3.7 | 3.3 | 49.6 | 50.5 | 43.6 | 23.6 | 33.2 | 32.9 |
| Cx | 0.140 | 0.144 | 0.142 | 0.238 | 0.223 | 0.252 | 0.688 | 0.677 | 0.679 |
| Cy | 0.060 | 0.057 | 0.059 | 0.702 | 0.711 | 0.693 | 0.304 | 0.310 | 0.310 |
| Peak wavelength (nm) | 457 | 456 | 456 | 531 | 529 | 533 | 640 | 629 | 629 |

R' auxiliary layer 62R' and an end portion of the R emission layer 62R overlap the other end portion of the G emission layer 62G.

[0091] As described above, the first thin film deposition assembly 100 (see FIG. 4) contains the deposition material for forming the B emission layer 62B, the second thin film deposition assembly 200 (see FIG. 4) contains the deposition material for forming the G' auxiliary layer 62G', the third thin film deposition assembly 300 (see FIG. 4) contains the deposition material for forming the G emission layer 62G, the fourth thin film deposition assembly 400 (see FIG. 4) contains the deposition material for forming the R' auxiliary layer 62R', and the fifth thin film deposition assembly 500 (see FIG. 4) contains the deposition material for forming the R emission layer 62R.

[0095] Alternatively, although it is not shown in the drawings, the first thin film assembly 100 may contain the deposition material for forming the B emission layer, the second thin film assembly 200 may contain the deposition material for forming the R' auxiliary layer, the third thin film deposition assembly 300 may contain the deposition material for forming the R emission layer, the fourth thin film deposition assembly 400 may contain the deposition material for forming G' auxiliary layer, and the fifth thin film deposition material 500 may contain the deposition material for forming the G emission layer.

[0096] In this case, the B emission layer is formed first, and then, the R' auxiliary layer is then formed. Here, a right end of the B emission layer and a left end of the R' auxiliary layer

overlap each other to some degree, and then, the left end of the R' auxiliary layer is deposited on the right end of the B emission layer. After that, the R emission layer is formed on the R' auxiliary layer. That is, the R' auxiliary layer is disposed between the B emission layer and the R emission layer, and thus the adjacent B emission layer and R emission layer do not directly contact each other.

[0097] Next, the G' auxiliary layer is formed. Here, a right end of the R emission layer and a left end of the G' auxiliary layer overlap each other to some degree, and then, the left end of the G' auxiliary layer is deposited on the right end of the R emission layer. After that, a G emission layer is formed on the G' auxiliary layer. That is, since the G' auxiliary layer is disposed between the R emission layer and the G emission layer, the adjacent R emission layer and G emission layer do not directly contact each other.

[0098] According to the current embodiment, degradation of the light emitting efficiency and the color mixture generated due to the overlapping of adjacent emission layers may be reduced.

[0099] Turning now to FIG. 6, FIG. 6 is a schematic perspective view of a thin film deposition assembly 700 according to a second embodiment of the present invention. Referring to FIG. 6, the thin film deposition assembly 700 according to the second embodiment of the present invention includes a deposition source 710, a deposition source nozzle unit 720, a first barrier plate assembly 730, a second barrier plate assembly 740, and a patterning slit sheet 750, for depositing a deposition material on a substrate 600.

[0100] Although a chamber is not illustrated in FIG. 6 for the convenience of explanation, all the components of the thin film deposition assembly 700 may be disposed within a chamber that is maintained at an appropriate degree of vacuum. The chamber is maintained at an appropriate vacuum in order to allow a deposition material to move in a substantially straight line through the thin film deposition assembly 700.

[0101] The substrate 600, which constitutes a deposition target on which a deposition material 115 is to be deposited, is disposed within the chamber. The deposition source 710 that contains and heats a deposition material 715 is disposed at an opposite side of the chamber to a side at which the substrate 600 is disposed. The deposition source 710 may include a crucible 711 and a heater 712.

[0102] The deposition source nozzle unit 720 is disposed at a side of the deposition source 710 facing the substrate 600. The deposition source nozzle unit 720 includes a plurality of deposition source nozzles 721 arranged at equal intervals in the X-axis direction.

[0103] The first barrier plate assembly 730 is disposed at a side of the deposition source nozzle unit 720. The first barrier plate assembly 730 includes a plurality of first barrier plates 731, and a first barrier plate frame 732 that covers sides of the first barrier plates 731. The first barrier plate frame 732 in the embodiment of FIG. 6 includes two opposing first barrier frame plates that are spaced from each other along the Y-axis direction with the first barrier plates 731 located therebetween. While the barrier frame plate on the left side in FIG. 6 appears as being less in height than the one on the right side, they may have the same height.

[0104] The second barrier plate assembly 740 is disposed at a side of the first barrier plate assembly 730. The second barrier plate assembly 740 includes a plurality of second

barrier plates 741, and a second barrier plate frame 742 that covers sides of the second barrier plates 741.

[0105] The patterning slit sheet 750 and a frame 755, in which the patterning slit sheet 755 is bound, are disposed between the deposition source 710 and the substrate 600. The frame 755 may be formed in a lattice shape, similar to a window frame. The patterning slit sheet 750 includes a plurality of patterning slits 751 arranged in the X-axis direction, the patterning slits 751 extending in the Y-axis direction.

[0106] The thin film deposition assembly 700 according to the second embodiment of the present invention includes two separate barrier plate assemblies, i.e., the first barrier plate assembly 730 and the second barrier plate assembly 740.

[0107] The plurality of first barrier plates 731 may be arranged parallel to each other at equal intervals in the X-axis direction. In addition, each of the first barrier plates 731 may be formed to extend along a YZ plane in FIG. 10, i.e., perpendicular to the X-axis direction.

[0108] The plurality of second barrier plates 741 may be arranged parallel to each other at equal intervals in the X-axis direction. In addition, each of the second barrier plates 741 may be formed to extend parallel to the YZ plane in FIG. 710, i.e., perpendicular to the X-axis direction.

[0109] The plurality of first barrier plates 731 and second barrier plates 741 arranged as described above partition the space between the deposition source nozzle unit 720 and the patterning slit sheet 750. In the thin film deposition assembly 700 according to the second embodiment of the present invention, the deposition space is divided by the first barrier plates 731 and the second barrier plates 741 into sub-deposition spaces that respectively correspond to the deposition source nozzles 721 through which the deposition material 715 is discharged.

[0110] The second barrier plates 741 may be disposed to correspond respectively to the first barrier plates 731. In other words, the second barrier plates 741 may be respectively disposed to be parallel to and to be on the same plane as the first barrier plates 731. Each pair of the corresponding first and second barrier plates 731 and 741 may be located on the same plane. As described above, since the space between the deposition source nozzle unit 720 and the patterning slit sheet 750, which will be described later, is partitioned by the combination of the first barrier plates 731 and the second barrier plates 741, which are disposed parallel to each other, the deposition material 715 discharged through one of the deposition source nozzles 721 is not mixed with the deposition material 715 discharged through the other deposition source nozzles 721, and is deposited on the substrate 600 through the patterning slits 751. In other words, the first barrier plates 731 and the second barrier plates 741 guide the deposition material 715, which is discharged through the deposition source nozzles 721, and prevent the deposition material 715 from flowing in the X-axis direction.

[0111] Although the first barrier plates 731 and the second barrier plates 741 are respectively illustrated in FIG. 6 as having the same thickness in the X-axis direction, the present invention is not limited thereto. In other words, the second barrier plates 741, which need to be accurately aligned with the patterning slit sheet 750, may be formed to be relatively thin, whereas the first barrier plates 731, which do not need to be precisely aligned with the patterning slit sheet 750, may be formed to be relatively thick. This makes it easier to manufacture the thin film deposition assembly.

[0112] Although not illustrated, a thin film deposition apparatus according to the second embodiment of the present invention may include a plurality of thin film deposition assemblies as in FIG. 4, each of which has the structure illustrated in FIG. 6. In other words, the thin film deposition apparatus according to the second embodiment of the present invention may include a multi-deposition source that sequentially discharges deposition materials for forming a blue emission (B) layer, a green auxiliary (G') layer, a G emission layer, a red auxiliary (R') layer, and a R emission layer. Deposition is performed in a scanning manner while the substrate 600 is moved in a direction of an arrow C in FIG. 6. Since the plurality of thin film deposition assemblies have been described in detail in the first embodiment, a detailed description thereof will not be provided here.

[0113] Turning now to FIGS. 7 through 9, FIG. 7 is a schematic perspective view of a thin film deposition assembly 1100 according to a third embodiment of the present invention, FIG. 8 is a schematic sectional view of the thin film deposition assembly 1100 illustrated in FIG. 7, and FIG. 9 is a schematic plan view of the thin film deposition assembly 1100 illustrated in FIG. 7. Referring to FIGS. 7, 8 and 9, the thin film deposition assembly 1100 according to the third embodiment of the present invention includes a deposition source 1110, a deposition source nozzle unit 1120, and a patterning slit sheet 1150.

[0114] Although a chamber is not illustrated in FIGS. 7, 8 and 9 for the convenience of explanation, all the components of the thin film deposition assembly 1100 may be disposed within a chamber that is maintained at an appropriate degree of vacuum. The chamber is maintained at an appropriate vacuum in order to allow a deposition material to move in a substantially straight line through the thin film deposition assembly 1100.

[0115] The substrate 600, which constitutes a deposition target on which a deposition material 1115 is to be deposited, is disposed in the chamber. The deposition source 1110 that contains a crucible 1111 and a heater 1112 and heats the deposition material 1115, is disposed at an opposite side of the chamber to a side at which the substrate 600 is disposed.

[0116] The deposition source nozzle unit 1120 is disposed at a side of the deposition source 1110, and in particular, at the side of the deposition source 1110 facing the substrate 600. The deposition source nozzle unit 1120 includes a plurality of deposition source nozzles 1121 arranged at equal intervals in the Y-axis direction, i.e., a scanning direction of the substrate 600. The deposition material 1115 that is vaporized in the deposition source 1110 passes through the deposition source nozzle unit 1120 towards the substrate 600. As described above, when the deposition source nozzle unit 1120 includes the plurality of deposition source nozzles 1121 arranged in the Y-axis direction, that is, the scanning direction of the substrate 600, the size of a pattern made out of the deposition material discharged through the patterning slits 1150 of the patterning slit sheet 1151 is affected by the size of one of the deposition source nozzles 1121 (since there is only one line of deposition nozzles in the Y-axis direction), and thus no shadow zone may be formed on the substrate 600. In addition, since the plurality of deposition source nozzles 1121 are arranged in the scanning direction of the substrate 600, even if there is a difference in flux between the deposition source nozzles 1121, the difference may be compensated for and deposition uniformity may be maintained constant.

[0117] The patterning slit sheet 1150 and a frame 1155 in which the patterning slit sheet 1155 is bound are disposed between the deposition source 1110 and the substrate 600. The frame 1155 may be formed in a lattice shape, similar to a window frame. The patterning slit sheet 1150 is bound inside the frame 1155. The patterning slit sheet 1150 includes a plurality of patterning slits 1151 arranged in the X-axis direction, each slit with openings that extend in the Y-axis direction. The deposition material 1115 that is vaporized in the deposition source 1110 passes through the deposition source nozzle unit 1120 and the patterning slit sheet 1150 towards the substrate 600. The patterning slit sheet 1150 may be manufactured by etching, which is the same technique as used in a conventional technique of manufacturing an FMM, and in particular, a striped FMM.

[0118] In addition, the deposition source 1110 and the deposition source nozzle unit 1120 coupled to the deposition source 1110 may be disposed to be separated from the patterning slit sheet 1150 (e.g., separated by a predetermined distance). Alternatively, the deposition source 1110 and the deposition source nozzle unit 1120 coupled to the deposition source 1110 may be connected to the patterning slit sheet 1150 by a connection member 1135. That is, the deposition source 1110, the deposition source nozzle unit 1120, and the patterning slit sheet 1150 may be integrally formed as one body by being connected to each other via the connection member 1135. The connection member 1135 guides the deposition material 1115, which is discharged through the deposition source nozzles 1121, to move straight in the Z-axis direction and not to flow in the X-axis direction. In FIG. 7, the connection members 1135 are formed on left and right sides of the deposition source 1110. The connection member 1135, the deposition source nozzle unit 1120 and the patterning slit sheet 1150 guide the deposition material 1115 to prevent deposition material 1115 from flowing in the X-axis direction, however, aspects of the present invention are not limited thereto. That is, the connection member 1135 may be formed as a sealed box to limit the flow of the deposition material 1115 both in the X-axis and Y-axis directions.

[0119] As described above, the thin film deposition assembly 1100 according to the third embodiment of the present invention performs deposition while being moved relative to the substrate 600. In order to move the thin film deposition assembly 1100 relative to the substrate 600, the patterning slit sheet 1150 must be spaced apart from the substrate 600 (e.g., spaced apart by a predetermined distance).

[0120] As described above, according to the described embodiments of the present invention, a mask is formed to be smaller than a substrate, and deposition is performed while the mask is moved relative to the substrate. Thus, the mask can be easily manufactured. In addition, defects caused due to contact between a substrate and a FMM, which occur in the conventional deposition technique, may be prevented. Furthermore, since it is unnecessary to dispose the FMM in close contact with the substrate during a deposition process, the manufacturing time may be reduced.

[0121] Although not illustrated, a thin film deposition apparatus according to the third embodiment of the present invention may include a plurality of thin film deposition assemblies as in FIG. 4, each of which has the structure illustrated in FIGS. 7 through 9. In other words, the thin film deposition apparatus according to the third embodiment of the present invention may include a multi-deposition source that sequentially discharges deposition materials for forming

a blue emission (B) layer, a green auxiliary (G') layer, a G emission layer, a red auxiliary (R') layer, and a R emission layer. Deposition is performed in a scanning manner while the substrate 600 is moved in a direction of an arrow A in FIG. 7. Since the plurality of thin film deposition assemblies have been described in detail in the first embodiment, a detailed description thereof will not be provided here.

[0122] Turning now to FIG. 10, FIG. 10 is a schematic perspective view of a thin film deposition assembly 1200 according to a fourth embodiment of the present invention. Referring to FIG. 10, the thin film deposition assembly 1200 according to the current embodiment of the present invention includes a deposition source 1210, a deposition source nozzle unit 1220, and a patterning slit sheet 1250. In particular, the deposition source 1210 includes a crucible 1211 that is filled with the deposition material 1215, and a heater 1212 that heats the crucible 1211 to vaporize the deposition material 1215, which is contained in the crucible 1211, so as to move the vaporized deposition material 1215 to the deposition source nozzle unit 1220. The deposition source nozzle unit 1220, which has a planar shape, is disposed at a side of the deposition source 1210 closest to the substrate 600. The deposition source nozzle unit 1220 includes a plurality of deposition source nozzles 1221 arranged in the Y-axis direction. The patterning slit sheet 1250 and a frame 1255 are further disposed between the deposition source 1210 and the substrate 600. The patterning slit sheet 1250 includes a plurality of patterning slits 1251 arranged in the X-axis direction, each slit extending along the Y-axis direction. In addition, the deposition source 1210 and the deposition source nozzle unit 1220 may be connected to the patterning slit sheet 1250 by the connection member 1235.

[0123] In the fourth embodiment and unlike the third embodiment of FIGS. 7, 8, and 9, a plurality of deposition source nozzles 1221 formed in the deposition source nozzle unit 1220 are tilted (e.g., tilted at a predetermined angle). In particular, the deposition source nozzles 1221 may include deposition source nozzles 1221a and 1221b arranged in respective rows. The deposition source nozzles 1221a and 1221b may be arranged in respective rows to alternate in a zigzag pattern. The deposition source nozzles 1221a and 1221b may be tilted by a predetermined angle with respect to an YZ plane.

[0124] The deposition source nozzles 1221a of a first row and the deposition source nozzles 1221b of a second row may tilt to face each other. That is, the deposition source nozzles 1221a of the first row in a left part of the deposition source nozzle unit 1220 may tilt to face a right side portion of the patterning slit sheet 1250, and the deposition source nozzles 1221b of the second row in a right part of the deposition source nozzle unit 1220 may tilt to face a left side portion of the patterning slit sheet 1250.

[0125] Turning now to FIGS. 11 and 12, FIG. 11 is a graph showing a distribution of a deposition film formed on the substrate 600 when the deposition source nozzles 1221a and 1221b are not tilted in the thin film deposition assembly 1200 according to the current embodiment of the present invention, and FIG. 12 is a graph showing a distribution of a deposition film formed on the substrate 600 when the deposition source nozzles 1221a and 1221b are tilted, in the thin film deposition assembly 1200. Comparing the graphs of FIGS. 11 and 12 with each other, the thickness of the deposition film formed on opposite end portions of the substrate 600 when the deposition source nozzles 1221a and 1221b are tilted is relatively

greater than that of the deposition film formed on the substrate 600 when the deposition source nozzles 1221a and 1221b are not tilted, and thus, the uniformity of the deposition film is improved.

[0126] Due to the structure of the thin film deposition assembly 1200 according to the fourth embodiment, the deposition of the deposition material 1215 may be adjusted to lessen a thickness variation between the center and the end portions of the substrate 600 and improve thickness uniformity of the deposition film. Moreover, utilization efficiency of the deposition material 1215 may also be improved.

[0127] As described above, in a thin film deposition apparatus according to embodiments of the present invention, a method of manufacturing an organic light-emitting display device according to embodiments of the present invention by using the thin film deposition apparatus, and an organic light-emitting display device manufactured by using the technique, the thin film deposition apparatus may be simply applied to the manufacture of large-sized display devices on a mass scale. In addition, the thin film deposition apparatus and the organic-light-emitting display device may be easily manufactured, and may improve manufacturing yield and deposition efficiency.

[0128] Instead of using a single fine metal mask (FMM) to produce the deposition pattern, a smaller patterning slit sheet is employed and moved relative to the substrate during deposition. Hence, in a large display, it is no longer necessary to use a very large FMM. Multiple deposition layers can be deposited in a single deposition step by having many deposition sources moving together. Auxiliary layers may be further included to prevent one color emission layer from directly contacting another color emission layer. Barrier plates may further be included between the patterning slit sheet and the deposition source to guide the evaporated deposition material while allowing for recovery of deposition material that fails to deposit. The nozzles may run parallel to or perpendicular to the slits of the patterning slit sheet. The nozzles may further be formed in two rows, each row having the nozzles tilted towards the other row to produce a more uniform deposition film.

[0129] Hereinafter, a composition of overall system of a thin film deposition apparatus comprising a plurality of thin film deposition assemblies of FIG. 4 will be described in detail. In other embodiments, the overall system of a thin film deposition apparatus may include any combination of the thin film deposition assemblies of FIG. 4, FIG. 6, FIG. 7 and or FIG. 10.

[0130] FIG. 13 is a schematic plan view of a thin film deposition apparatus according to an embodiment of the present invention. FIG. 14 illustrates a modified example of the thin film deposition apparatus of FIG. 13. FIG. 15 is a cross-sectional view of an example of an electrostatic chuck 800 according to an embodiment of the present invention.

[0131] Referring to FIG. 13, the thin film deposition apparatus includes a loading unit 910, a deposition unit 930, an unloading unit 920, a first conveyer unit 810, and a second conveyer unit 820.

[0132] The loading unit 910 may include a first rack 912, a transport robot 914, a transport chamber 916, and a first inversion chamber 918. A plurality of substrates 600 onto which a deposition material is not applied are stacked up on the first rack 912. The transport robot 914 picks up one of the substrates 600 from the first rack 912, places the substrate 600 on the electrostatic chuck 800 transferred by the second con-

veyor unit **820**, and moves the electrostatic chuck **800** on which the substrate **600** is placed into the transport chamber **916**.

[0133] The first inversion chamber **918** is located adjacent to the transport chamber **916**. The first inversion chamber **918** includes a first inversion robot **919** that inverts the electrostatic chuck **800** and then loads it into the first conveyer unit **810** of the deposition unit **930**.

[0134] Referring to FIG. 15, the electrostatic chuck **800** may include an electrode **802** embedded in a main body **801** formed of ceramic, wherein the electrode **802** is supplied with power. The substrate **600** may be fixed to a surface of the main body **801** of the electrostatic chuck **800** as a high voltage is applied to the electrode **802**.

[0135] Referring back to FIG. 13, the transport robot **914** places one of the substrates **600** on the surface of the electrostatic chuck **800**, and the electrostatic chuck **800** on which the substrate **600** is placed is moved into the transport chamber **916**. The first inversion robot **919** inverts the electrostatic chuck **800** so that the substrate **600** is turned upside down in the deposition unit **930**.

[0136] The unloading unit **920** is constituted to operate in an opposite manner to the loading unit **910** described above. Specifically, a second inversion robot **929** in a second inversion chamber **928** inverts the electrostatic chuck **800**, which has passed through the deposition unit **930** while the substrate **600** is placed on the electrostatic chuck **800**, and then moves the electrostatic chuck **800** on which the substrate **600** is placed into an ejection chamber **926**. Then, an ejection robot **924** removes the electrostatic chuck **800** on which the substrate **600** is placed from the ejection chamber **926**, separates the substrate **600** from the electrostatic chuck **800**, and then loads the substrate **600** into the second rack **922**. The electrostatic chuck **800** separated from the substrate **600** is returned back into the loading unit **910** via the second conveyer unit **820**.

[0137] However, aspects of embodiments according to the present invention are not limited to the above description. For example, when placing the substrate **600** on the electrostatic chuck **800**, the substrate **600** may be fixed onto a bottom surface of the electrostatic chuck **800** and then moved into the deposition unit **930**. In this case, for example, the first inversion chamber **918** and the first inversion robot **919**, and the second inversion chamber **928** and the second inversion robot **929**, may not be required.

[0138] The deposition unit **930** may include at least one deposition chamber. As illustrated in FIG. 13, the deposition unit **930** may include a first chamber **931**. In this case, first to fourth thin film deposition assemblies **100**, **200**, **300**, and **400** may be located in the first chamber **931**. Although FIG. 13 illustrates that a total of four thin film deposition assemblies, i.e., the first to fourth thin film deposition assemblies **100** to **400**, are installed in the first chamber **931**, the total number of thin film deposition assemblies that may be installed in the first chamber **931** may vary according to a deposition material and deposition conditions. The first chamber **931** is maintained in a vacuum state during a deposition process.

[0139] In the thin film deposition apparatus illustrated in FIG. 14, a deposition unit **930** may include a first chamber **931** and a second chamber **932** that are connected to each other. In this case, first and second thin film deposition assemblies **100** and **200** may be located in the first chamber **931**, and third and fourth thin film deposition assemblies **300** and **400** may be located in the second chamber **932**. In other embodi-

ments, additional chambers may be added, such that any suitable number of chambers may be used.

[0140] In the embodiment illustrated in FIG. 13, the electrostatic chuck **800** on which the substrate **600** is placed may be moved at least to the deposition unit **930** or may be moved sequentially to the loading unit **910**, the deposition unit **930**, and the unloading unit **920**, by the first conveyer unit **810**. The electrostatic chuck **800** that is separated from the substrate **600** in the unloading unit **920** is moved back to the loading unit **910** by the second conveyer unit **820**.

[0141] While the present invention has been particularly shown and described with reference to exemplary embodiments thereof, it will be understood by those of ordinary skill in the art that various changes in form and details may be made thereto without departing from the spirit and scope of the present invention as defined by the following claims and their equivalents.

What is claimed is:

1. An organic light-emitting display device comprising a plurality of pixels, wherein each of the pixels comprises:
 - a G sub-pixel that includes a G emission layer and a G auxiliary layer;
 - a R sub-pixel that includes a R emission layer and a R auxiliary layer; and
 - a B sub-pixel that includes a B emission layer, wherein the G auxiliary layer is arranged between the B emission layer and the G emission layer, and the R auxiliary layer is arranged between the G emission layer and the R emission layer.
2. The organic light-emitting display device of claim 1, wherein an end portion of the G auxiliary layer overlaps an end portion of the B emission layer, the G emission layer being arranged on the G auxiliary layer.
3. The organic light-emitting display device of claim 1, wherein an end portion of the R auxiliary layer overlaps an end portion of the G emission layer, the R emission layer being arranged on the R auxiliary layer.
4. The organic light-emitting display device of claim 1, wherein the B emission layer and the G emission layer are separated from each other by a first distance, and the G emission layer and the R emission layer are separated from each other by a second distance.
5. The organic light-emitting display device of claim 1, further comprising:
 - a substrate; and
 - a first electrode and a second electrode arranged opposite to each other, wherein the B, G, and R emission layers and the G and R auxiliary layers are arranged between the first and second electrodes.
6. The organic light-emitting display device of claim 1, wherein the G auxiliary layer and the R auxiliary layer have different thicknesses from each other.
7. An organic light-emitting display device comprising a plurality of pixels, wherein each of the pixels comprises:
 - a G sub-pixel that includes a G emission layer and a G auxiliary layer;
 - a R sub-pixel that includes a R emission layer and a R auxiliary layer; and
 - a B sub-pixel that includes a B emission layer, wherein the R auxiliary layer is arranged between the B emission layer and the R emission layer, and the G auxiliary layer is arranged between the R emission layer and the G emission layer.

8. The organic light-emitting display device of claim 7, wherein an end portion of the R auxiliary layer overlaps an end portion of the B emission layer, the R emission layer being arranged on the R auxiliary layer.

9. The organic light-emitting display device of claim 7, wherein an end portion of the G auxiliary layer overlaps an end portion of the R emission layer, the G emission layer being arranged on the G auxiliary layer.

10. The organic light-emitting display device of claim 7, wherein the B emission layer and the R emission layer are spaced apart by a first distance, the R emission layer and the G emission layer are spaced apart by a second distance.

11. The organic light-emitting display device of claim 7, further comprising:

a substrate; and

a first electrode and a second electrode arranged opposite to each other, wherein the B, G, and R emission layers and the G and R auxiliary layers are arranged between the first and second electrodes.

12. The organic light-emitting display device of claim 7, wherein the G auxiliary layer and the R auxiliary layer have different thicknesses from each other.

* * * * *

